

SmartSensor Advance

USER GUIDE

SmartSensor Advance

USER GUIDE

© 2012 Wavetronix LLC. All Rights Reserved.

Wavetronix, SmartSensor, Click, Command, and all associated product names and logos are trademarks of Wavetronix LLC. All other products or brand names as they appear are trademarks or registered trademarks of their respective holders.

Protected by U.S. Patent Nos. 6,556,916; 6,693,557; 7,426,450; 7,427,930; 7,573,400; 7,889,097; 7,889,098; 7,924,170; 7,991,542; Canadian Patent No. 2461411; 2434756; and European Patent Nos. 1435036; 1438702; 1611458. Other U.S. and international patents pending.

The Company shall not be liable for any errors contained herein or for any damages arising out of or related to this document or the information contained therein, even if the Company has been advised of the possibility of such damages.

This document is intended for informational and instructional purposes only. The Company reserves the right to make changes in the specifications and other information contained in this document without prior notification.

FCC Part 15 Compliance: The Wavetronix SmartSensor sensors comply with Part 15 of the Federal Communications Commission (FCC) rules which state that operation is subject to the following two conditions: (1) this device may not cause harmful interference, and (2) this device must accept any interference received, including interference that may cause undesirable operation. FCC compliance statements for applicable optional modules are to be found in the module specifications. Unauthorized changes or modifications not expressly approved by the party responsible for compliance with the FCC rules could void the user's authority to operate this equipment.

Disclaimer: The advertised detection accuracy of the Wavetronix SmartSensor sensors is based on both external and internal testing, as outlined in each product's specification document. Although our sensors are very accurate by industry standards, like all other sensor manufacturers we cannot guarantee perfection or assure that no errors will ever occur in any particular applications of our technology. Therefore, beyond the express Limited Warranty that accompanies each sensor sold by the company, we offer no additional representations, warranties, guarantees or remedies to our customers. It is recommended that purchasers and integrators evaluate the accuracy of each sensor to determine the acceptable margin of error for each application within their particular system(s).

Contents

Chapter 1	Introduction	5
	SmartSensor Advance Package 6 • Selecting a Detection Method 6 • Selecting a Mounting Location 8	

Part I **Installing the SmartSensor Advance**

Chapter 2	Installing the SmartSensor Advance	15
	Selecting the Mounting Height 15 • Attaching the Mount Bracket to the Pole 16 • Attaching the Sensor to the Mount Bracket 16 • Aligning the Sensor to the Roadway 17 • Applying Silicon Dielectric Compound 19 • Connecting the Smart-Sensor 6-conductor Cable 20 • Grounding the Sensor 21	

Chapter 3	Connecting Power and Surge Protection	23
	Mounting the Backplate 24 • Connecting AC Power 24 • Providing System Surge Protection 28 • Terminating the 6-conductor Cables 30 • Contact Closure Connections 32	

Part II **Using SmartSensor Manager Advance**

Chapter 4	Installing SmartSensor Manager Advance	35
	Installing SSMA 35	

Chapter 5	Communication	39
	Serial Connection 40 • Internet Connection 41 • Virtual Connection 42 • Multi-drop Network 45 • Address Book 46 •	

	Viewing Connection Information 46 • Uploading the Sensor's Embedded Software 49	
Chapter 6	Sensor Settings General Tab 51 • Communication Tab 52	51
Chapter 7	Sensor Configuration 1. Installation Details 56 • 2. Automatic Radar Configuration 58 • 3. Manual Radar Adjustment 59	55
Chapter 8	Channels-Alerts-Zones Channels 66 • Alerts 76 • Zones 76	65
Chapter 9	Verify Channels-Alerts-Zones Right Sidebar 84 • Roadway Display 90 • Left Sidebar 97	83
Chapter 10	Setup Output Communications Configuring Data Push Parameters 101	101
Chapter 11	Templates Creating a Channel Template 106 • Importing a Channel Template 106 • Copying/Pasting Channels, Alerts and Zones 108	105
Chapter 12	Tools Backup/Restore Tool 110 • Beam Alignment Tool 113 • Serial Terminal 114 • Rack Card Tools 115	109
Chapter 13	Programming Contact Closures Click 112/114 Contact Closure Cards 119 • Click 172/174 Contact Closure Cards 120 • Click 104 Contact Closure Module 123	119
Chapter 14	Appendix Appendix A – Cable Connector Definitions 127 • Appendix B – Appendix B - Cable Lengths 129 • Appendix C – Direct Serial Connections 132 • Appendix D – Target Roll Angles for Alignment 133	127

Introduction

In this chapter

- SmartSensor Advance Package
- Selecting a Detection Method
- Selecting a Mounting Location

The Wavetronix SmartSensor Advance™ and Wavetronix SmartSensor Advance Extended Range detect and continuously monitor the progression of moving traffic out to a maximum range of 600 ft. (182.9 m) and 900 ft. (274.3 m) respectively.

Both traffic sensors are designed for use on the approaches to signalized intersections. They are used to alert the traffic controller of a vehicle's arrival based upon the incoming range, speed, and estimated time-of-arrival of each detected vehicle for applications such as high-speed dilemma zone protection and queue reduction. In addition, SmartSensor Advance Extended Range allows you to prioritize dilemma zone protection based upon the discovery range of trucks and passenger cars.

SmartSensor Advance and SmartSensor Advance Extended Range monitor vehicle traffic flow through the use of a 10.525 GHz (X band) operating radio frequency. Both sensors utilize Digital Wave Radar™ technology to provide a reliable Frequency Modulated Continuous Wave. SmartSensor Advance Extended Range uses a new form of frequency modulation to achieve its extended reach.

The SmartSensor Advance User Guide is divided into two parts. Part one provides a step-by-step process for installing the SmartSensor Advance and the SmartSensor Advance Extended Range, including mounting and alignment guidelines. Part two provides instructions for installing and using the SmartSensor Manager Advance software, including in-

structions for both automatic and manual sensor configurations. Any questions about the information in this guide should be directed to Wavetronix or your distributor.

Caution

Do not attempt to service or repair this unit. This unit does not contain any components and/or parts serviceable in the field. Any attempt to open this unit, except as expressly written and directed by Wavetronix, will void the customer warranty. Wavetronix is not liable for any bodily harm or damage caused if service is attempted or if the back cover of the SmartSensor unit is opened. Refer all service questions to Wavetronix or an authorized distributor.

SmartSensor Advance Package

A typical SmartSensor Advance package will commonly include:

- 10.525 GHz SmartSensor Advance radar traffic sensor
- SmartSensor mounting kit
- SmartSensor 6-conductor cable
- SmartSensor Advance preassembled backplate
- SmartSensor Manager Advance (SSMA) software
- SmartSensor Advance User Guide
- SmartSensor Advance Quick-reference Guides

Check the packing slip for actual contents. If any of these items are missing, note the serial number located on the back of the sensor and contact your distributor.

Selecting a Detection Method

Consult the Wavetronix guidelines for integration of SmartSensor Advance into your traffic control system. For dilemma zone protection applications, integration guidelines can be found on the Wavetronix website and Wavetronix application notes. Contact your dealer or a Wavetronix Technical Services representative if the application-specific documentation does not fully answer your system integration and configuration questions.

Some examples of traffic control applications include:

- Dilemma zone protection using green extension
- Truck signal priority using green extension
- Dilemma zone protection using green extension with an Advanced Warning Sign (AWS)
- Dilemma zone protection using red extension

- Queue clearance
- Efficient green extension
- Queue management

Note

For queue management the SmartSensor Advance Extended Range is recommended because it allows you to see a greater range and also provides a view of the stop bar. The SmartSensor Advance Extended Range is also recommended for wrong-way detection applications. Contact Wavetronix Technical Services for more information.

If your application is dilemma zone protection and/or truck signal priority, SafeArrival™ technology is recommended because it provides significant safety and efficiency advantages when compared with traditional point-based protection. Configuring SafeArrival technology for dilemma zone protection is as simple as selecting the arrival times, ranges and speeds that are unsafe and warrant protection. Configuration SafeArrival technology for truck signal priority requires the additional configuration of the truck discovery range threshold available with SmartSensor Advance Extended Range.

For green extension, arrival times between 2.5 and 5.5 seconds, ranges from 100 to 500 ft. (30.5 to 152.4 m) and speeds above 35 mph (56 kph) are generally considered unsafe for passenger vehicles. For truck signal priority, arrival times between 2.5 and 7.5 seconds, ranges from 100 to 900 ft. (30.5 to 274.3 m) and speeds above 35 mph (56 kph) are generally considered unsafe for trucks, buses and other large vehicles.

However, engineering judgment needs to be used in selecting these parameters. For example, 2.5 to 5.5 second arrival times are nominal values based upon general 10% and 90% stopping probabilities. Your agency may suggest protection of slightly different arrival times for a particular type of high-speed approach.

It may be helpful to consult your agency's guidelines to verify which traffic conditions warrant protection at your intersections. Location of point-detection zones, passage time and design speed can often be used to infer the arrival times and ranges that warrant protection. In addition, the minimum speed that would warrant installation of a dilemma zone protection system may be used as a guideline for the lowest speed to be protected.

If you elect not to use SafeArrival technology, you can also configure SmartSensor Advance to match your agency's loop-based dilemma zone protection guidelines. Before doing so, it is recommended that you explore the benefits provided by SafeArrival technology in detail.

Selecting a Mounting Location

Consider the following guidelines when selecting a mounting location:

- Detection coverage** – Position the sensor so that it will be able to reach all the specified advanced detection zones. Also consider that the sensor will track vehicles as they enter and exit desired detection zones. Accordingly, the sensor will often work better if you position detection coverage to track vehicles for several feet before they reach the first zone. The closest detection zone provided by SmartSensor Advance and SmartSensor Advance Extended Range is 50 ft. (15.2 m) from the location of the sensor. The farthest detection zone provided by SmartSensor Advance Extended Range is 900 ft. (274.3 m). The farthest detection zone provided by SmartSensor Advance is 600 ft. (182.9 m). The sensor can detect incoming or outgoing traffic, and filters out the opposite direction traffic. Usually the sensor is used to detect incoming traffic. With SmartSensor Advance Extended Range, incoming large vehicles are typically discovered by about 750 ft. (228.6 m) and small vehicles are typically discovered about 600 ft (182.9 m) from the sensor. With SmartSensor Advance, most incoming large vehicles are discovered by about 500 ft. (152.4 m) and most small vehicles are discovered about 400 ft (121.9) from the sensor.

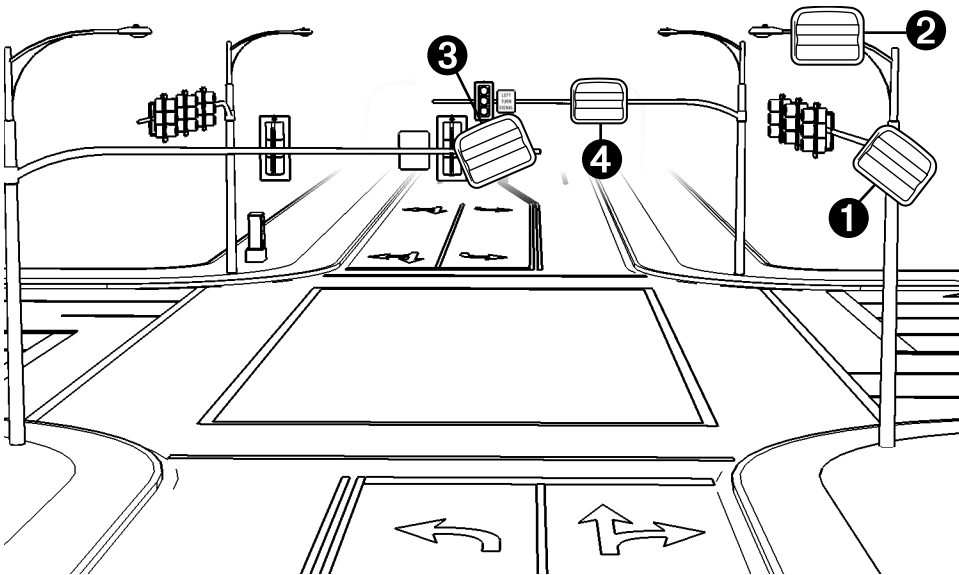

Figure I.1 – Mounting Locations

- Line-of-sight** – Position the sensor so that it will have line-of-sight to the entire detection area of interest. Avoid structural occlusion including trees, signs, and other roadside structures.
- Closest roadside** – If you install the sensor on the side of the road (instead of overhead), select the location closest to the lanes of interest. This will prevent departing traffic from occluding approaching detections.
- Through-Movement Detection** – If only through-movement detection is desired, po-

sition the sensor to avoid detection of turn-only lanes. Consider using speed filters to remove the impact of turning vehicles.

- **Mounting Height** - Mounting the sensor as high as possible is recommended to reduce same lane occlusion. A maximum of 40 ft. (12.2 m) and minimum of 17 ft. (5.2 m) is recommended. If the sensor is higher than 30 ft. (9.1 m), the offset should be less than 50 ft. (15.2 m) to increase accuracy.
- **Mounting Offset** - Mounting the sensor closer to the lanes of interest will usually increase detection accuracies. A maximum offset of 50 ft. (15.2 m) is recommended, but the sensor will still reliably track vehicles at further offsets. Mounting with a smaller offset will generally increase line-of-sight.
- **Cable Length** - Make sure that you have sufficient homerun and sensor cabling. With the newer models, cable runs as long as 1500 ft. (457.2 m) are achievable using 24 VDC operation and RS-485 communications. Older models supported up to 600 ft. (182.9 m). Consult Appendix B for more information.
- **Suspended Electrical Cables** - The sensor is designed to work in the presence of suspended power lines and other electrical cabling, however these cables should be mounted at least ten feet away from the front of the sensor.
- **Neighboring Structures and Parallel Walls** - For best performance, it is preferred that the sensor be mounted without signs or other flat surfaces mounted directly behind it. This will help reduce multiple reflection paths from a single vehicle.

The SmartSensor Advance should be mounted using one of the following options (see Figure I.1):

- 1 **On a vertical pole** - The preferred mounting location for the SmartSensor Advance or SmartSensor Advance Extended Range is often a vertical pole near the stop bar. Vertical poles are typically installed on the roadside of the approach near the stop bar to support a mast arm, span wire or luminaire. These poles often extend as high as 30 ft. (9.1 m) or more, allowing the sensor to be mounted high enough to reduce occlusion. This mounting location is typically very safe for installation.
- 2 **On a luminaire** - This mounting location will often reduce the offset and increase the mounting height (a maximum of 40 ft. (12.2 m) is recommended). Make sure the luminaire can support the load of the sensor. This mounting location is typically very safe for installation.
- 3 **The backside of the opposing mast arm** - By mounting on the backside of the mast arm, opposite the signal heads for the opposing direction of travel, the sensor can be placed near the lanes of interest. The minimum mounting height is 17 ft. (5.2 m), but higher mounting is recommended to minimize occlusion. When appropriate, a vertical extension can be used; the extension should have the ability to freely rotate the sensor for alignment. The sensor should be mounted as far out on the mast arm as possible to avoid potential occlusion issues with stopped vehicles in a left-turn pocket.
- 4 **The front side of the mast arm** - The sensor can be installed on the mast arm with the signals for the approach of interest. SmartSensor Advance Extended Range is recommended at this mounting location, because typically 100 feet or more of the sensor's range is used to cross the width of the intersection. For SmartSensor Advance Extended Range, the effective maximum range of the sensor is still as high as 800 feet

from the stop bar at this mounting location. This mounting location is also recommended on approaches where dynamic red extension will be used in tandem with the green extension. This mounting location can also be helpful if the minimum green time is so short that vehicles in the queue clearance zone do not start moving before the minimum green timer expires.

The SmartSensor Advance or SmartSensor Advance Extended Range can also be mounted at the back of the dilemma zone on an existing luminaire or custom pole if the luminaire already exists, power is available and a wireless communication link can be used to avoid trenching. Wavetronix has integrated wireless solutions readily available for this type of installation.

Part 1

Installing the SmartSensor Advance

Chapter 1 - Installing the SmartSensor Advance

Chapter 2 - Connecting Power and Surge Protection

Installing the SmartSensor Advance

In this chapter

- Selecting the Mounting Height
- Attaching the Mount Bracket to the Pole
- Attaching the Sensor to the Mount Bracket
- Aligning the Sensor to the Roadway
- Applying Silicon Dielectric Compound
- Connecting the SmartSensor Cable to the Sensor

Installing the SmartSensor Advance is quick and easy. Once installed, SmartSensor Advance requires little or no on-site maintenance. This chapter describes the installation process, including how to attach the sensor to the pole and how to correctly align the sensor.

Warning

Caution should be used when installing any sensor on or around active roadways. Serious injury can result when installation is performed using methods that are not in accordance with authorized local safety policy and procedures. Always maintain an appropriate awareness of the traffic conditions and safety procedures as they relate to specific locations and installations.

Selecting the Mounting Height

Select a mounting location within the recommended range of offsets from the center of

the lanes of interest. Offsets of less than 50 ft. (15.2 m) on either side of the center of the desired lanes are recommended.

The minimum recommended mounting height is 17 ft. (5.2 m) and the maximum recommended mounting height is 40 ft. (12.2 m). Higher than 30-ft. (9.1-m) mounting heights are acceptable if the sensor is within 50 ft. (15.2 m) of the road. Depending on the site and type of traffic, some vehicles may be momentarily occluded by other vehicles. Vehicle-based occlusion favors detection of large vehicles, which may be acceptable for dilemma zone protection applications. It may be necessary to increase the height of the sensor to reduce occlusion, or use controller passage time to bridge the gap caused by occlusion.

Attaching the Mount Bracket to the Pole

Before attaching the mount bracket to the pole, first make sure that your cables are long enough to support the sensor height and the distance from the sensor to the cabinet.

Follow the steps below to correctly attach the mount to the pole (see Figure 1.1):

- 1 Insert the stainless steel straps through the slots in the mount bracket.
- 2 Position the mount on the pole so that the head of the mount is pointing towards the middle of the lanes of interest.
- 3 Tighten the strap screws, but keep the straps adjustable for future sensor alignment.

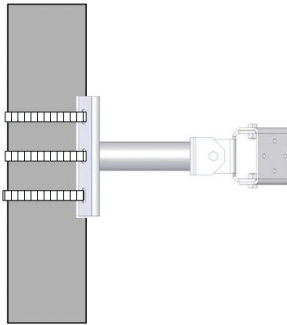

Figure 1.1 – Attaching the Mount Bracket to the Pole

Attaching the Sensor to the Mount Bracket

- 1 Align the bolts on the sensor's backplate with the holes in the mount bracket. The 8-pin connector on the sensor should be pointing towards the ground.
- 2 Place the lock washers onto the bolts after the bolts are in the mount bracket holes.
- 3 Thread on the nuts and tighten (see Figure 1.2).

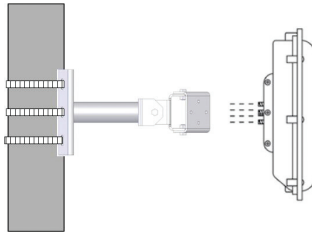

Figure 1.2 – Attaching the Sensor to the Mount Bracket

Aligning the Sensor to the Roadway

In most applications, the goal is to position the beam's elliptical footprint along the roadway. This is done by pointing the hot spot of the sensor's beam (middle of the sensor) at a target location, and then rolling the sensor so that the beam's footprint lines up with the road.

The standard sensor mount has three axes of rotation: straps around pole, vertical and horizontal swivel points. Make sure that your sensor mount's degrees of freedom are adjustable until you have completed your alignment.

Follow the steps below to correctly align the sensor:

- 1 Point the sensor towards the target on the road by tilting the sensor down and panning it to the left or right as necessary (see Figure 1.3). The target location is typically between 30 and 80 ft. (9.1 and 24.4 m) upstream from the sensor in the center of the lanes of interest. See Table 1.1 below to find the appropriate target distance.

		Height (ft / m)					
		17 / 5.2	20 / 6.1	25 / 7.6	30 / 9.1	35 / 10.7	40 / 12.2
Offset (ft / m)	0 / 0	40 / 12.2	45 / 13.7	55 / 16.8	60 / 18.3	70 / 21.3	75 / 22.9
	5 / 1.5	45 / 13.7	45 / 13.7	60 / 18.3	65 / 19.8	70 / 21.3	80 / 24.4
	10 / 3	50 / 15.2	50 / 15.2	60 / 18.3	65 / 19.8	75 / 22.9	80 / 24.4
	15 / 4.6	50 / 15.2	55 / 16.8	65 / 19.8	70 / 21.3	75 / 22.9	80 / 24.4
	20 / 6.1	55 / 16.8	55 / 16.8	65 / 19.8	75 / 22.9	80 / 24.4	90 / 27.4
	25 / 7.6	60 / 18.3	65 / 19.8	65 / 19.8	75 / 22.9	80 / 24.4	90 / 27.4
	30 / 9.1	65 / 19.8	70 / 21.3	75 / 22.9	80 / 24.4	85 / 25.9	95 / 28.9
	35 / 10.7	70 / 21.3	75 / 22.9	85 / 25.9	85 / 25.9	95 / 28.9	95 / 28.9
	40 / 12.2	80 / 24.4	90 / 27.4	90 / 27.4	95 / 28.9	95 / 28.9	100 / 30.4
	45 / 13.7	95 / 28.9	100 / 30.4	100 / 30.4	100 / 30.4	100 / 30.4	105 / 32
50 / 15.2	100 / 30.4	100 / 30.4	105 / 32	110 / 33.5	115 / 35	120 / 36.6	

Table 1.1 – Target Distance (ft / m)

To verify your pointing, look at the road from directly behind the sensor. If from this vantage point you do not see the target location, then the sensor is pointed in the right general direction.

Note

With roadside alignments, it may be beneficial to use a pointing assistant (e.g. a Quick-Grip beam clamp) for precise alignment. A beam clamp can be attached to the sensor and aimed by looking down the length of the beam to verify pointing.

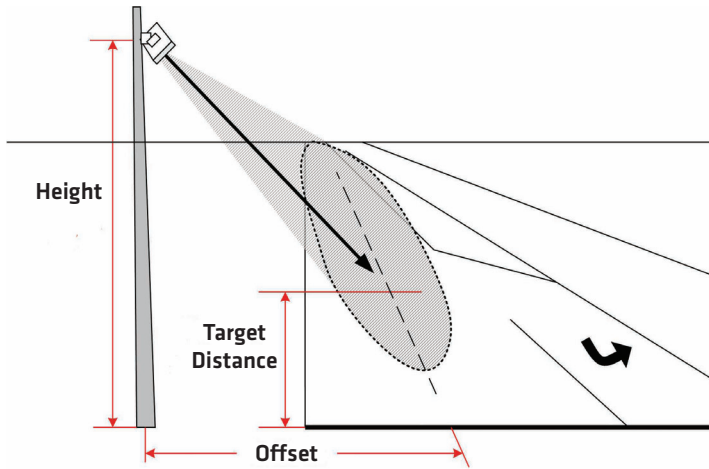

Figure 1.3 - Pointing the Sensor

- 2 Roll the sensor using the backplate, while keeping it pointed at the target location, to align the elliptical beam. If the sensor is mounted directly above the lanes of interest, you will not need to roll the sensor. (See Appendix D for target roll angles.)
- 3 Align the top and bottom center-tabs of the sensor with the center of the lanes of interest. It may be beneficial to use a 90 degree edge from a rafter's square or other framing device to correctly align the sensor. Place the parallel edge of the framing device on the top or bottom of the sensor and then line the perpendicular edge with the roadway (see Figure 1.4).

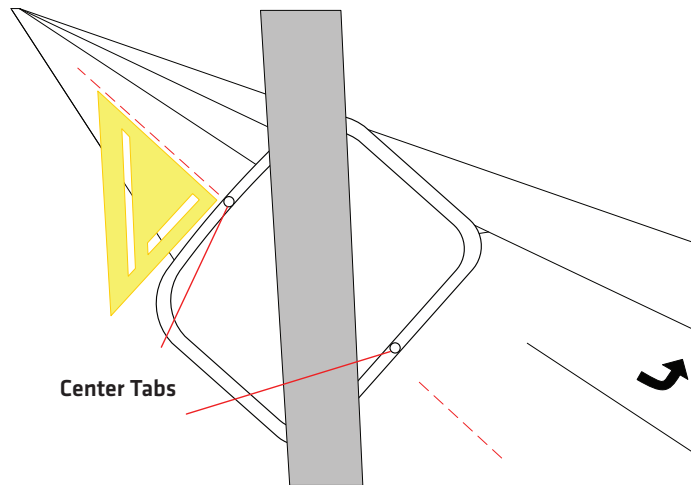

Figure 1.4 - Aligning the Sensor with the Roadway

- 4 Once the sensor is correctly pointed and rolled, secure the mounting bracket screws. The connector should be pointing towards the center of the lanes of interest.

If you are using the sensor on a curved road, you can aim the sensor so that it bisects the curve of the road and still hits your nearest and farthest ranges of interest. If the sensor is mounted near the outside edge of the curved road, you may be able to bisect the curve with little or no roll. If the road curves dramatically, you may need to reduce the down tilt of the sensor so that the beam fans out more at the far ranges. In order to help you visualize custom alignments like this, an alignment tool is available in the configuration software (see Beam Alignment Tool).

Applying Silicon Dielectric Compound

- 1 Tear the tab off the tube of silicon dielectric compound.
- 2 Squeeze about 25% of the silicon into the connector at the base of the SmartSensor Advance (see Figure 1.5).
- 3 Wipe off any excess compound.



Figure 1.5 - Connector Receptacle (left) and Grounding Lug (right)

Connecting the SmartSensor 6-conductor Cable

The next step is to plug the SmartSensor 6-conductor cable into the connector. The sensor connector is keyed to ensure proper connection (see Figure 1.6); simply twist the plug end of the connector clockwise until you hear it click into place.



Figure 1.6 - Sensor 6-conductor Cable Connector

To avoid undue movement from the wind, strap the 6-conductor cable to the pole or run it through a conduit, but leave a small amount of slack at the top of the cable to reduce cable strain. Route the cable from the sensor location back to the main traffic cabinet.

To set up your network in an orderly fashion, it is recommended that labeling be used on the service end of each SmartSensor 6-conductor cable. A convenient way to label the cables is to mark the last seven digits of the serial number on each sensor and the direction of traffic monitored (see Figure 1.7).



Figure 1.7 – Service End Labeling

Grounding the Sensor

The SmartSensor Advance must now be grounded:

- 1 Connect a grounding wire to the grounding lug on the bottom of the sensor (see Figure 1.5).
- 2 Connect the other end of the grounding wire to the earth ground for the pole that the sensor is mounted on. Do not attempt to run the grounding wire back to the main traffic cabinet.

Connecting Power and Surge Protection

2

In this chapter

- Mounting the Backplate
- Connecting AC Power
- Providing System Surge Protection
- Terminating the SmartSensor 6-conductor Cable
- Contact Closure Connections

After installation, each SmartSensor Advance will need to be integrated into the main traffic cabinet for power and surge protection. This chapter contains information on how to provide power and surge protection to the intersection preassembled backplate located in the main traffic cabinet.

The intersection preassembled backplate is 11 in. (28 cm) wide and 11.5 in. (29.2 cm) high. Also available to use are the intersection preassembled 19-inch rack for server racks and the intersection segmented preassembled backplate for easier installation in traffic cabinets. All wiring on the rack and backplates is done using stranded wires with wire ferrules for screw terminal connections (see Figure 2.1).

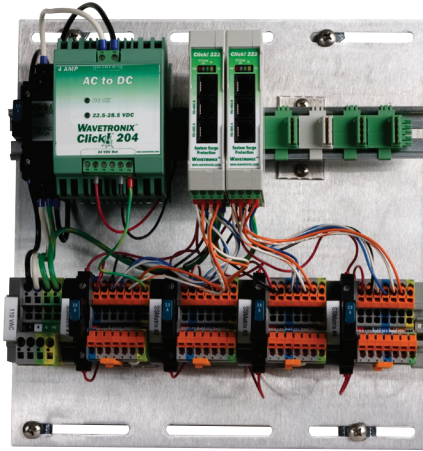

Figure 2.1 - Intersection Preassembled Backplate

Please refer to the Click quick-reference guides for more comprehensive product instructions. Chapter 12 contains information on how Click products make the sensor compatible with all standard control cabinets.

A pinout diagram showing the sensor cable's pin-out and appropriate connection points can be found in Appendix A of this document.

Mounting the Backplate

Use the following steps to mount the backplate in the traffic cabinet:

- 1 Locate the area planned for mounting the backplate. The backplate can usually be mounted on the side panel of a NEMA-style cabinet.
- 2 Attach the backplate with the U-channel mounting screws.

Note

If you have a 330 series (170/2070 style cabinet) with a 19-inch EIA rack, please contact Wavetronix Technical Services for assistance. Wavetronix can provide modified backplates that attach to a 19-inch rack.

Connecting AC Power

Since SmartSensor Advance operates on 10–28 VDC, the intersection preassembled backplates provide an AC power conversion option. The backplate includes an AC to DC power converter, power surge and circuit breaker.

Warning

Make sure power to AC mains is disconnected while wiring the AC input. If your installation does not require AC power, you will need to use surplus DC power inside the traffic cabinet. In this case, Wavetronix recommends you use the Click 221 (8 AC surge protector) to protect the backplate and SmartSensor Advance units from DC surges.

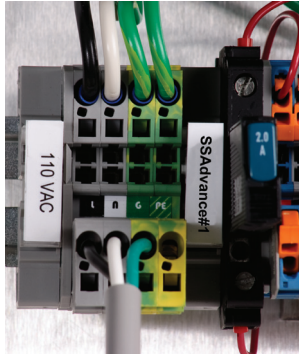

Figure 2.2 – Connecting AC Power to the Preassembled Backplate

Use the following steps to connect power to the AC terminal block on the bottom DIN rail (see Figure 2.2):

- 1** Connect a neutral wire (usually a white wire) to the bottom side of the terminal block labeled “N” for neutral.
- 2** Connect a ground wire (usually a green wire) to the bottom of the terminal block labeled “G” for ground. (see the Wiring Protective Earth Ground section below).
- 3** Connect a line wire (usually a black wire) to the bottom of the terminal block labeled “L” for line.
- 4** Turn on AC mains power.
- 5** Press the circuit breaker switch on the left side of the top DIN rail to switch power to the backplate. The switch is on if the button is below the level of the device housing; the switch is off if the button is raised above the surface of the housing.
- 6** Verify that DC power is properly regulated by making sure the DC OK LEDs are illuminated on the Click 201/202/204.

Caution

An authorized electrical technician should install the intersection preassembled backplate. Persons other than authorized and approved electrical technicians should NOT attempt to connect the backplate to a power supply and/or traffic control cabinet, as there is a serious risk of electrical shock through unsafe handling of the power source. Extreme caution should be used when connecting the backplate to an active power supply.

The AC power conversion section of the backplate will come pre-wired as shown in Figure 2.3. The three main components of the AC power conversion section include:

- **Click 201/202/204 AC to DC converter** – A Click 201 provides 1 A of power and is capable of powering a single sensor; a Click 202 provides 2 A and can power two sensors; a Click 204 provides 4 A and can power four sensors.
- **Click 210 circuit breaker** – Interrupts power during overload conditions and provides a convenient way to turn power on and off for the entire system.
- **Click 230 AC surge protector** – Helps protect equipment from current surges on the power lines.

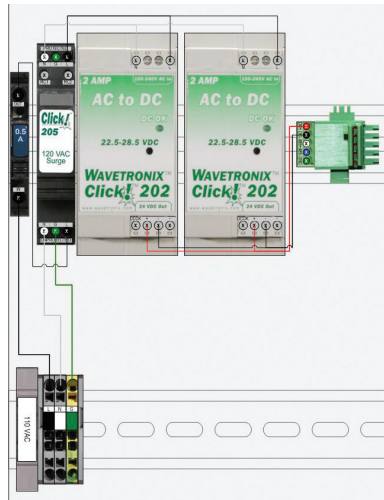

Figure 2.3 – AC Power Conversion

Wiring Protective Earth Ground

All connections are surge protected when the protective earth ground is wired to the PE terminal block on the backplate. Normally, the backplate should be mounted to the chassis of the cabinet to provide a ground path. It is strongly recommended that you provide a low impedance protective earth connection.

Follow the steps below to provide a low impedance protective earth connection:

- 1 Connect one end of a protective earth ground wire to the bottom of the PE terminal block. A 10 AWG stranded wire is recommended for protective earth ground connections and is also the largest that will fit in the terminal block.
- 2 Connect the other end of the protective earth ground wire to a protective earth screw terminal within the main traffic cabinet.

Controlling DC Power Distribution

The Click 210 circuit breakers provide a convenient way to turn power on or off for each sensor independently (see Figure 2.4). To enable or disable DC power to the backplate, press the main circuit breaker (left side of upper DIN rail); to enable or disable DC power to an individual sensor, press the individual circuit breaker (left side of each sensor's set of terminal blocks).

Push this button to
turn power on or off.

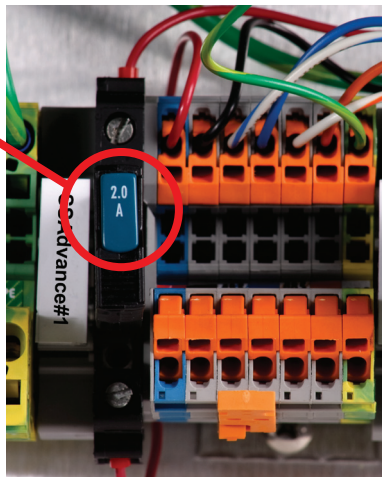

Figure 2.4 - DC Power Distribution

Note

The switch is ON when the switch button is level with the device housing; the switch is OFF when the switch button is raised above the housing.

The four-approach preassembled backplate has 24 VDC power wired from the output of the AC to DC convertor into a 5-position screw terminal on the left side of the T-bus (see Figure 2.5). The green T-bus conducts DC power and RS-485 communications from the left to the right side of the modules; the gray T-bus conducts only DC power from the left to the right side of the modules.

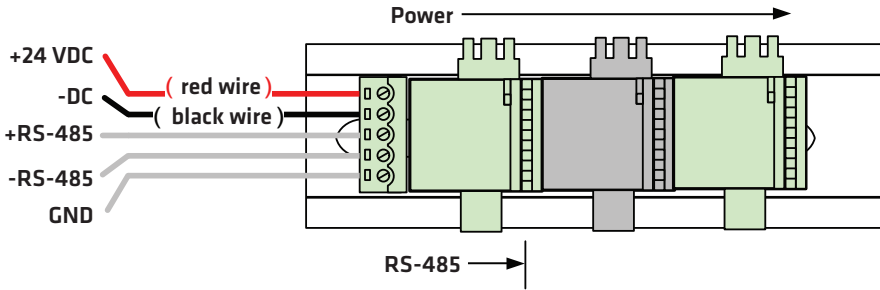

Figure 2.5 - T-bus Pinout Diagram

Providing System Surge Protection

The Click 222 system surge protector is designed to prevent electrical surges conducted along underground cables from damaging the cabinet equipment (see Figure 2.6).



Figure 2.6 - Click 222 Faceplate

Note

The SmartSensor Advance has built-in surge protection and so there is no need to use a pole-mount box for surge protection on the sensor side of the cable. However, it is strongly recommended that the sensor be connected to a surge protection device in the main traffic cabinet. If you choose not to use surge protection in your main traffic cabinet, please contact Wavetronix Technical Services for assistance.

When a Click 222 is present, the power and RS-485 serial connections on the T-bus and faceplate are protected from surges on the incoming SmartSensor 6-conductor cables.

The Click 222 faceplate has four activity indicator LEDs:

- **PWR** - Indicates that the device has power.

- **DC Surge OK** - Indicates that DC surge protection is operational.
- **TD** - Indicates when data is transmitted over the T-bus or over the control bridge. This LED does not indicate data transmitted on the A or B ports.
- **RD** - Indicates when data is received over the T-bus or over the control bridge. This LED does not indicate data received on the A or B ports.

Note

If the DC Surge OK LED is not on when the Click 222 is powered, call Wavetronix Technical Services for assistance.

The Click 222 provides the following three independent serial connections:

- **Top jack** - control bridge
- **Middle jack** - dedicated communications for sensor 2 detection calls
- **Bottom jack** - dedicated communications for sensor 1 detection calls

The control bridge enables a multi-drop shared communication bus between all sensors connected to the backplate. This allows control of all Advance sensors, rack cards and other connected Click devices. The remaining two serial connection ports provide communications to only one sensor each, as outlined above.

On a four-sensor preassembled backplate (see Figure 2.7):

- The sensor wired into the leftmost terminal blocks will be connected to ports A and C on the Click 222 on the left. Port A is for detection calls and port C is connected to the control bridge.
- The sensor wired to the second set of terminal blocks will be wired to ports B and D on the Click 222 on the left. Port B is for detection calls and port D is connected to the control bridge.
- The sensor wired to the third set of terminal block from the left will be wired to ports A and C on the Click 222 on the right.
- The sensor wired to the rightmost terminal block will be wired to ports B and D on the Click 222 on the right.

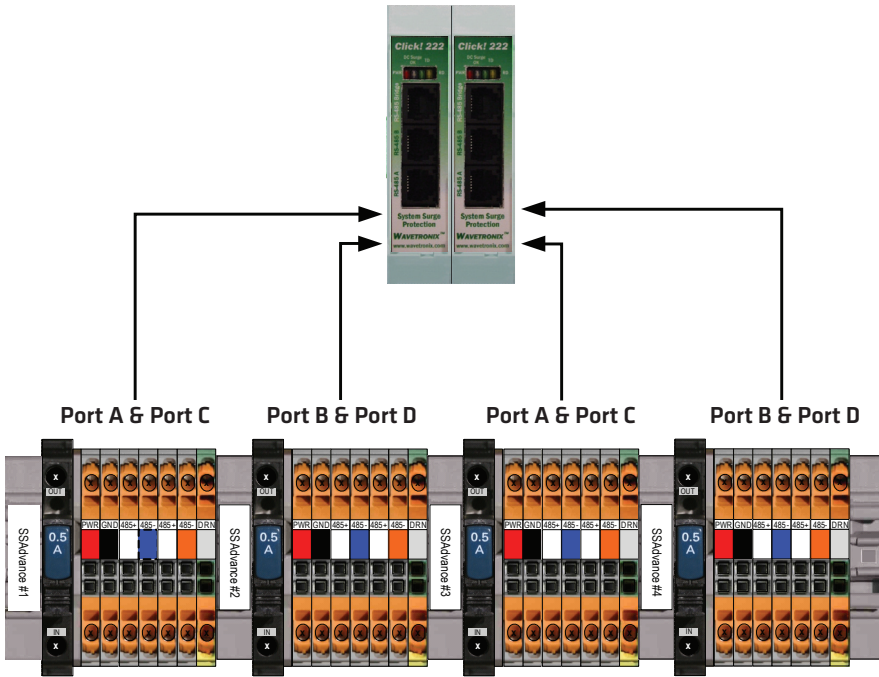

Figure 2.7 – Click! 222 Ports A, B, C and D

Terminating the 6-conductor Cables

The SmartSensor Advance will receive power once each SmartSensor 6-conductor cable is correctly landed into the plug-in terminals on the backplate (see Figure 2.10 and Table 2.1). Each 6-conductor cable has one DC power wire pair, two RS-485 communication pairs and a drain wire. The service end of the cable connects to plug-in terminals on the backplate (see Figure 1.8).

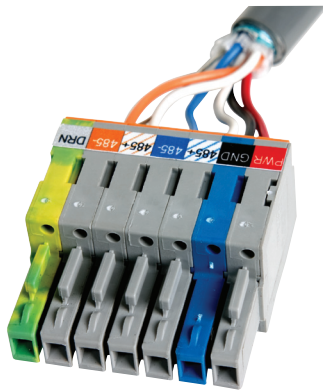

Figure 2.8 – Color Label on Plug-in Terminals

Note

Do not strip the service end of the cable until after it has been routed through conduit. The cable should be one continuous run without any splices.

Use the steps below to land the sensor cables:

- 1 After routing your SmartSensor 6-conductor cable into the cabinet, carefully strip back the cable jacket and shielding on the service end of the cable.
- 2 Open the insulation displacement connectors on the plug by inserting a small screwdriver into each square slot and rocking it back.
- 3 Insert the wire leads into the bottom side of the plug-in terminal according to the color code shown in Table 2.1 and Figure 2.10. Make sure the wires are completely inserted in the terminal.
- 4 Close the insulation displacement connector by reinserting the screwdriver into the square slot and rocking it forward. The plug-in terminals will automatically complete the electrical connection. There is no need to manually strip the insulation on the end of each wire.

There are two measures in place to ensure that the plugs are always returned to their correct terminal block sections.

- First, for visual confirmation, one part of the plug is blue (see Figure 2.10) and must be visually matched up to a blue terminal block. The location of the blue piece rotates in the different plugs and terminal block sections: in the first, the first block is blue, in the second, the second is blue, etc.
- Second, the plugs are keyed (see the blue piece in Figure 2.10) so they will only fit into their correct terminal block sections.

Wire Color	Signal
Red (PWR)	DC+
Black (GND)	DC-
White with Blue stripe (485+)	Control bridge 485+ (port1)
Blue (485-)	Control bridge 485 - (port 1)
White with Orange stripe (485+)	Data bus 485+ (port 2)
Orange (485-)	Data bus 485- (port 2)
Bare metal (DRN)	Drain

Table 2.1 – Cable Wiring Color Code

Contact Closure Connections

The SmartSensor Advance now supports both the Click 112/114 and Click 172/174 cards. SmartSensor Advance Extended Range only supports Click 112/114. Use the data bus ports (A or B) on the Click 222 to connect to the contact closure cards. In some cases, several contact closure cards can be daisy-chained together. However, if you are using the Click 172/174 cards, the chain should not be connected until each card has been independently programmed (see Figure 2.11).



Figure 2.9 – Connecting Contact Closure Modules

Note

Wait to connect contact closure communications until after the sensor is programmed using the configuration software.

See Chapter 12 for more information on contact closure communications.

Part II

Using SmartSensor Manager Advance

Chapter 3 - Installing SmartSensor Manager Advance

Chapter 4 - Communication

Chapter 5 - Sensor Settings

Chapter 6 - Sensor Configuration

Chapter 7 - Channels-Alerts-Zones

Chapter 8 - Verify Channels-Alerts-Zones

Chapter 9 - Setup Output Communications

Chapter 10 - Templates

Chapter 11 - Tools

Chapter 12 - Programming Contact Closure Cards

Installing SmartSensor Manager Advance

3

In this chapter

- Installing SSMA
- Microsoft .NET Framework

After the SmartSensor Advance is installed, use SmartSensor Manager Advance (SSMA) to configure the sensor to the roadway and change sensor settings. SmartSensor Manager Advance is software that enables users to configure and interact with the SmartSensor Advance (SS200).

This part of the user guide is designed to illustrate SSMA functionality and describes the basic steps and procedures needed to correctly configure the SmartSensor Advance.

Installing SSMA

The SSMA software can be run on a Windows® PC and on a handheld computer running Windows Mobile. Everything needed to install SSMA to a PC is contained in the **SSM Advance v3.0 Setup.exe** file.

Note

You must have administrator rights to run the setup program.

Note

Microsoft .NET Framework version 3.5 or higher needs to be installed on your computer before installing SSMHD. You can get the .NET Framework from the Microsoft website.

Follow these steps to install SSMA on a PC:

- 1 To download the install file, go to the Wavetronix website at www.wavetronix.com.
- 2 Click the **Support** link near the top of the page. This will bring up a page with icons from the three different Wavetronix product lines.
- 3 Click the SmartSensor icon. This will bring up drop-down menus allowing you to select a product by name or part number.
- 4 Select **SmartSensor Advance** and a list of links will appear.
- 5 Select the **SmartSensor Manager Advance** link (under **Software**) to download the SSMA install file.
- 6 Once you've downloaded the file, double-click on it. This will execute a setup program that will copy all the necessary files to the hard drive and place icons in the Start menu and on the desktop of the PC or laptop (see Figure 3.1).

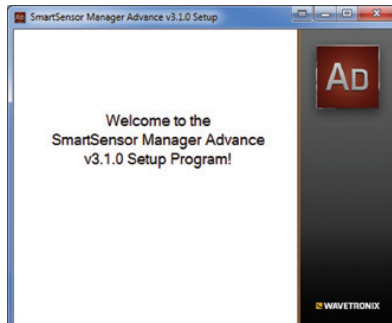

Figure 3.1 – SSMA Setup Wizard

- 7 Select an installation location. The default location provided is normally “C:\Program Files\Wavetronix.” Click **Browse** to choose another location (see Figure 3.2).

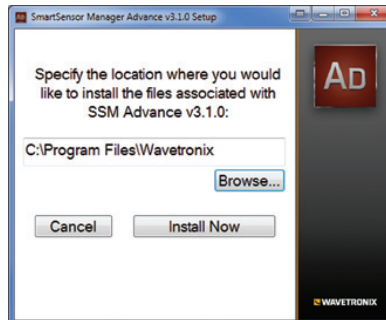

Figure 3.2 – Location Installation

- 8 Click the **Install Now** button.
- 9 After SSMA is installed, you can create shortcuts to the SSMA software on the desktop and in the start menu using the corresponding checkboxes (see Figure 3.3). If no shortcuts are desired, uncheck the corresponding boxes.

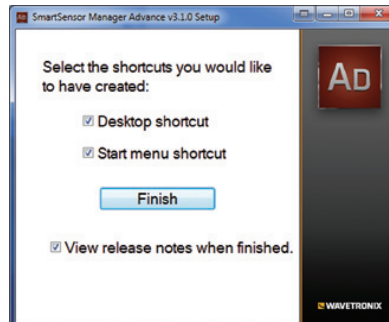

Figure 3.3 – Shortcut Options

- 10 Click in the **View release notes when finished** checkbox to view the SSMA v3 release notes. The release notes contain additional information about the current version of the SSMA software. A PDF reader program (i.e. Adobe Acrobat Reader) is required to view the release notes.
- 11 Click **Finish** to complete the setup process.

Installing SSMA on a Handheld Computer

If you would like to run SSMA on a handheld computer, consider purchasing a Wavetronix Install Kit, which includes a Socket Mobile SoMo 650 handheld computer that comes preconfigured with SmartSensor Manager Advance, as well as Click Supervisor and the SmartSensor Manager software programs for the other Wavetronix sensors. These software programs are tested for and supported on the SoMo 650.

SSMA can also be installed and will function on a handheld computer other than the SoMo 650. However, because of differing handheld computer technology, Wavetronix does not support any other handheld devices.

Use these steps to install SSMA on a handheld computer running Windows Mobile:

- 1 Ensure the handheld computer is connected to the PC and synced.
- 2 Click on the **SSM Advance v3 Setup.exe** file to run the setup program on the host computer. The SSMA Setup Wizard will automatically check the host computer to see if Microsoft ActiveSync (Windows XP and older) or Windows Mobile Device Center (Windows Vista) is installed. These are programs that are used to communicate with a handheld device. If one of these programs is found, the option of installing SSMA to a Pocket PC device will become available.
- 3 Click the **Pocket PC** checkbox and then the **Next>>** button to install SSMA on a connected Pocket PC device (see Figure 3.4). If both the Computer and Pocket PC boxes are checked, the setup program will first install the SSMA software to the computer.

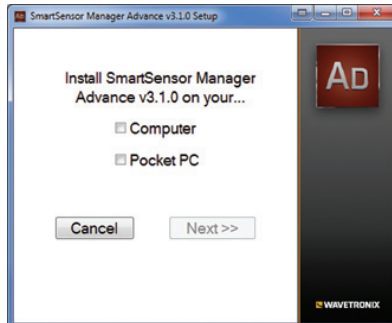

Figure 3.4 – Pocket PC Installation Program

- 4 Click **Continue>>** to start the Pocket PC installation process (see Figure 3.5). The setup program runs the Add/Remove Programs application for Windows handheld devices. If a Pocket PC device is connected to the computer, Add/Remove Programs will immediately begin installing SSMA on the Pocket PC device. If a Pocket PC device is not connected to the computer, SSMA will be downloaded the next time a Pocket PC device is connected to the computer.

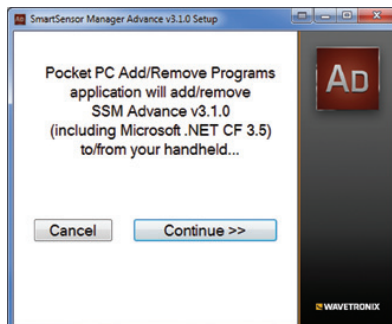

Figure 3.5 – Adding SSMA to a Pocket PC

- 5 Click **OK** once the download is complete.

In this chapter

- Serial Connection
- Internet Connection
- Virtual Connection
- Multi-drop Network
- Address Book
- Viewing Connection Information
- Uploading the Sensor's Embedded Software

Once the sensors are installed, use the SSMA software to change settings, view data and configure the sensors to the roadway.

Launch SSMA by either clicking on the icon that was placed on your desktop or clicking the icon found in the Start menu. The SSMA main screen shown in Figure 4.1 will appear.

If you are using SSMA on a laptop computer, you can use the panel in the lower left of the main screen to change the size of the user interface on your computer. Click any of the three squares to increase or decrease the size of the user interface.

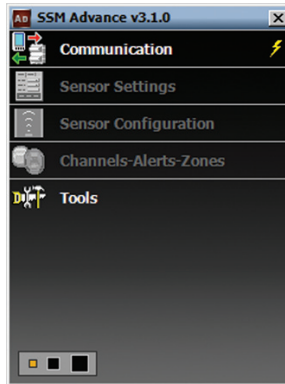

Figure 4.1 - SSMA Main Screen

The first step is to make a connection to the sensor. The following three types of connections can be made:

- **Serial connection** - Made using RS-485 communication.
- **Internet connection** - Made using an IP address and Serial-to-Ethernet adapter.
- **Virtual connection** - Made for convenience in learning and demonstrating SSMA functionality.

Communication settings are stored in the system registry each time a connection is established. After the first connection is made to the SmartSensor Advance, the SSMA software will save the connection settings that were used. Click the lightning bolt icon on the right side of the communication job area to make a connection using the most-recently-used parameters stored in the registry.

Serial Connection

- 1 Click on **Communication** to access the Communication window (see Figure 4.2).
- 2 Select the **Serial** tab.
- 3 Set Port and Speed to the desired settings. The SSMA software defaults to 9600 baud; this baud rate is recommended and most likely will not need to be changed. Click the **Advanced...** button for additional serial settings.
- 4 Click the **Connect** button.

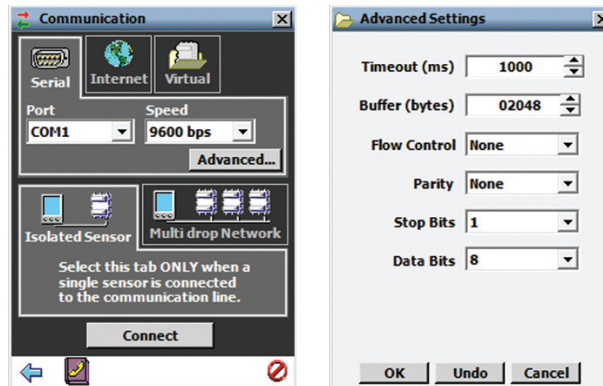

Figure 4.2 - Serial Connection (left) and Advanced Settings (right)

The Advanced Settings screen contains the following fields:

- **Timeout (ms)** - Allows you to set an additional amount of time (in milliseconds) that SSMA will wait for a response when communicating with the sensor.
- **Buffer (bytes)** - Contains the number of bytes used by SSMA to store data received from the sensor.
- **Parity** - This should always be set to None.
- **Stop Bits** - This should always be set to 1.
- **Data Bits** - This should always be set to 8.

Note

When a connection is made using the **Isolated Sensor** tab instead of the **Multi-drop Network** tab, the software will connect to the first sensor it finds. If you have multiple sensors and want to be able to connect to each one, use the **Multi-drop Network** tab (see Multi-drop Network section below).

Internet Connection

- 1 Click on **Communication**.
- 2 Select the **Internet** tab (see Figure 4.3).
- 3 Enter the IP address of the Serial-to-Ethernet adapter to which the sensor of interest is connected, or the domain name associated with the sensor in the Address field. The IP address is four octets, each ranging from 0-255, separated by dots (“.”). An URL address can also be entered into this field (i.e. sensor.earlink.com).
- 4 Enter the port number assigned to the Ethernet-to-Serial adapter in the Port field. This will be an integer value in the range of 0-65536. If you are using a Click 301 device, the default port number will be 10001. Click the **Advanced...** button for ad-

ditional Internet settings.

- 5 Click the **Connect** button.

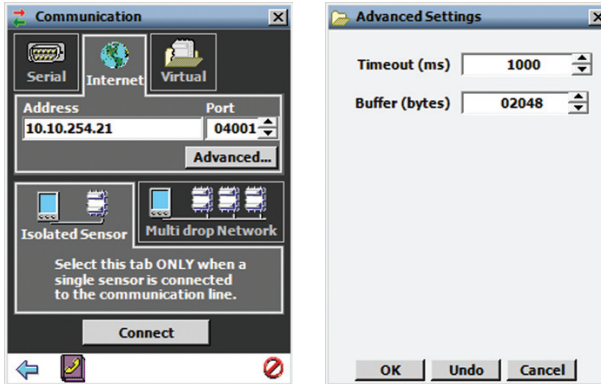

Figure 4.3 – Internet Connection (left) and Advanced Settings (right)

The Advanced Settings screen contains the following fields:

- **Timeout (ms)** – Allows you to set an additional amount of time (in milliseconds) that SSMA will wait for a response when communicating with the sensor.
- **Buffer (bytes)** – Contains the number of bytes used by SSMA to store data received from the sensor.

Virtual Connection

A virtual connection allows you to use the SSMA software without being connected to an actual sensor. Making a virtual connection can be useful for the following reasons:

- To view a saved sensor setup file.
- To play back previously logged traffic.
- To demonstrate functionality for different applications.
- To create channel templates.
- To review how the software works.

To make a virtual connection:

- 1 Click the **Communication** button.
- 2 Select the **Virtual** tab (see Figure 4.4).
- 3 Select a virtual sensor file by clicking the magnifying glass icon. Click the **Options...** button to select a tracker log file.
- 4 Click the **Connect** button.

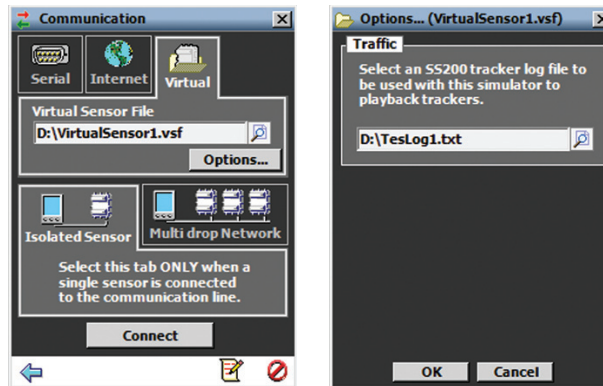

Figure 4.4 – Virtual Connection and Additional Options Screen

Virtual Sensor File

Since a virtual connection is not made to an actual sensor, a virtual sensor file (.vsf) is used to save the configuration settings much like an actual sensor's Flash memory. If you are making a virtual connection for the first time, you will need to create a virtual sensor file by clicking on the magnifying glass icon and entering a file name.

When you create a new virtual sensor, you will need to complete two steps. First, you need to open the new file (see Figure 4.5).

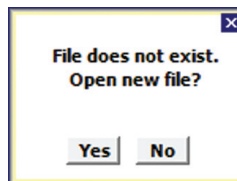

Figure 4.5 – Open New File

Second, you will need to decide whether the new sensor is to be a virtual SmartSensor Advance Extended Range device of a virtual SmartSensor Advance device (see Figure 4.6). If you would like the virtual sensor to emulate SmartSensor Advance Extended Range, answer **Yes** to the second prompt. If you would like the virtual sensor to emulate SmartSensor Advance answer **No** to the second prompt.

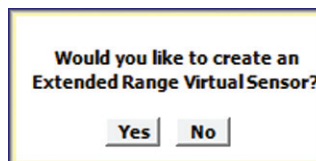

Figure 4.6 – Type of Virtual Sensor

Note

When you are connected using a virtual sensor file, changes that would normally be saved to a sensor's Flash memory will automatically be saved to the virtual sensor file.

Backing up a virtual sensor file will change the file to a sensor setup file (.ssc) that can be restored to an actual sensor. To convert a sensor setup file to a virtual sensor file, make a virtual connection and then use the Restore Sensor Setup tool in the Tools menu. To convert a virtual sensor file to a sensor setup file, use the Back-up Sensor Setup tool.

Note

If you want to configure channels, alerts and zones for a future installation, you can connect using a virtual connection, create a virtual sensor file and then back up the configuration settings that you created. After the file is successfully backed up, the virtual sensor file will change to a sensor setup file and can be restored to any sensor in the field.

Selecting a Tracker Log File

A tracker log file is used to play back recorded traffic. To select a tracker log file, click the **Options...** button, click on the magnifying glass icon and select the tracker log file from a list of existing files. If a tracker log file doesn't exist, the SSMA software will create a generic looping traffic pattern (see the Setup Channels-Alerts-Zones screen for instructions on how to create a tracker log file).

Note

If a successful connection uses the sensor's Com port that was being used to push data, the data push will be suspended during the duration of the connection.

When a connection is made to the SmartSensor Advance, the main menu will appear and all configuration options will become available (see Figure 4.7).

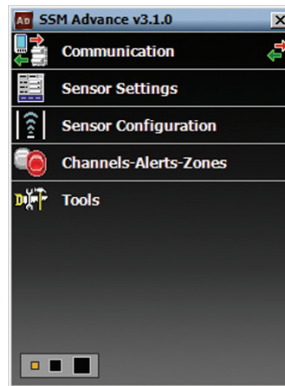

Figure 4.7 – SSMA Main Menu (Connected)

If you have problems connecting:

- 1 Make sure that all power and communication wiring is correct.
- 2 Check the port settings (baud rate, port ID).

Connection failure can occur for various reasons; if a failure occurs repeatedly, call Watervonix Technical Support at 801-764-0277 for assistance.

Multi-drop Network

The SSMA software automatically discovers the multi-drop ID of sensors over the selected port (normally you will auto-discover addresses over port 1).

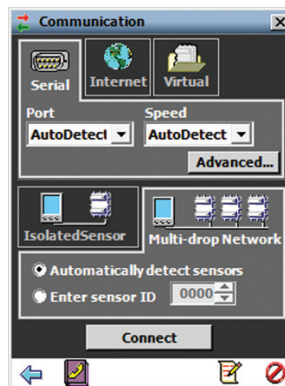

Figure 4.8 – Multi-drop Network

Click the **Automatically detect sensors** radio button and then click the **Connect** button. The Auto-Discovery window will appear with a list of each detected sensor and its device ID, location and description (see Figure 4.9).

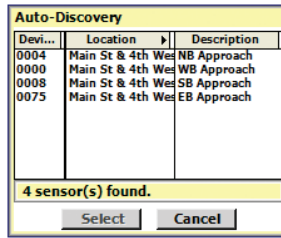

Figure 4.9 – Auto-Discovery Window

The device IDs are based on the last four digits of the sensor's serial number. If the sensor IDs conflict, they can be changed in the auto-discovery window by clicking on the desired row. The Change sensor ID window will appear allowing you to change the sensor ID.

Address Book

The address book allows you to save device connection settings for future use. Click the **Address Book** button located at the bottom of the Communication page to add new connection settings to the address book (see Figure 4.10).

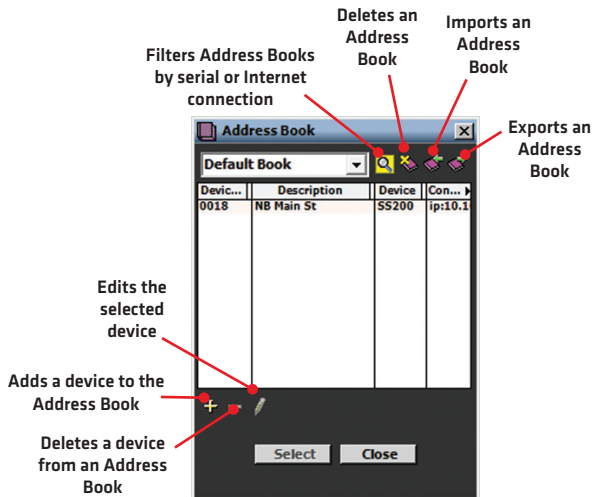

Figure 4.10 – Address Book and Address Book Filter

Viewing Connection Information

Once connected, you can view additional information about the connection you have established by clicking on the moving arrows icon on the top-right of the main menu page or on the bottom-right of the Communication screen (see Figure 4.11).

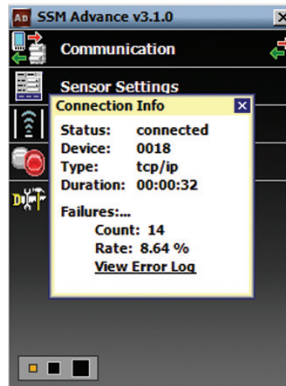

Figure 4.11 – Connection Info Screen

Below is a list of the information available on the Connection Info screen:

- **Status** - Shows that you are connected.
- **Device** - Shows the Subnet and sensor ID.
- **Type** - Shows the type of connection and baud rate.
- **Duration** - Shows how long you have been connected.
- **Failures** - Shows the amount of failures during the connection, the percentage rate of failure and a link to the Communication Error Log.

Check Hardware

After you have connected to a sensor, you can check its hardware type by right-clicking below the Tools menu option and selecting **Sensor Versions**.

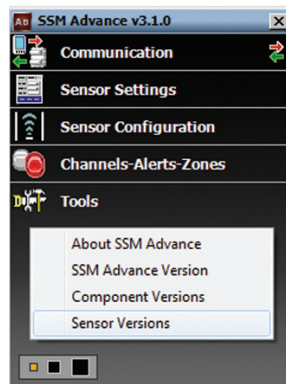

Figure 4.12 – Check Sensor Version

The two current hardware types are SmartSensor Advance and SmartSensor Advance Extended Range.

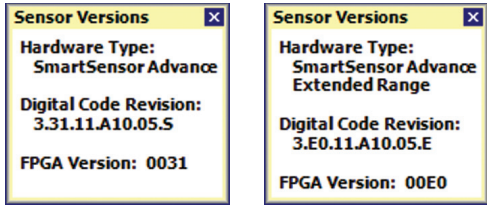

Figure 4.13 – Sensor Versions Window for Advance (left) and Advance Extended Range (right)

Once connected, the hardware type can also be determined from the title bar. If the sensor is an Extended Range sensor, it will say "(Ext. Range)" in the title bar of SSMA.

Communication Error Log

The error log contains all errors stored in the sensor’s memory buffer. If you are having trouble connecting, using the error log may be helpful in the troubleshooting process. If you continue having trouble, save the error log file and contact Wavetronix Technical Services.

Note

You will need to save the error log file or it will be overwritten.

Click the **View Error Log** link to view the communications error log (see Figure 4.14). The error log can also be accessed by clicking on the Error Log icon at the bottom of the Communication screen.

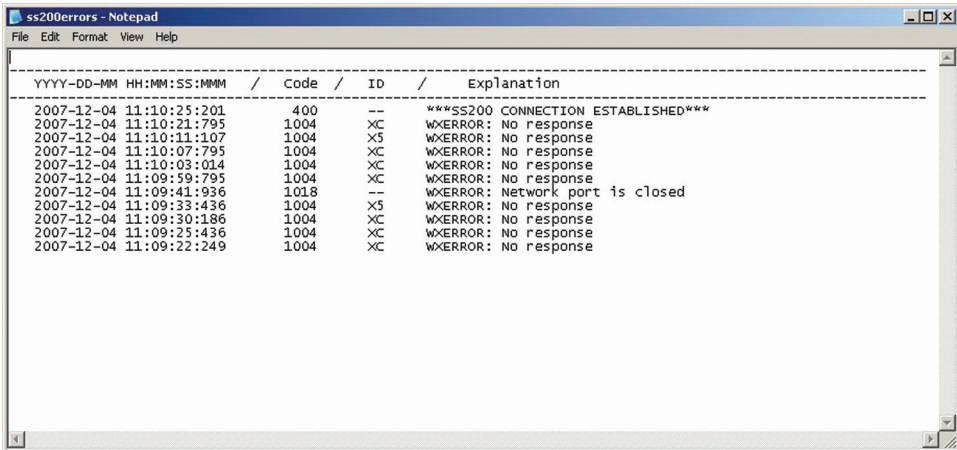

Figure 4.14 – Error Log

Uploading the Sensor's Embedded Software

After clicking the **Connect** button, the Version Control screen may appear notifying you that the sensor's embedded software and the firmware embedded in the SSMA software are not the same version (see Figure 4.15). To view more software version information, right-click on the SSMA main menu page and select from the options that appear.

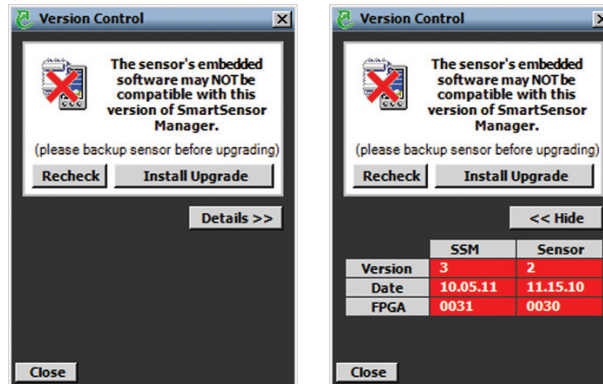

Figure 4.15 – Sensor's Embedded Software Upgrade (left) and Details Table (right)

Click the **Details** button to view the firmware versions of both the SSMA software and the sensor.

Once the Version Control screen appears, you can do one of the following:

- 1 Upgrade the sensor's embedded software by clicking the **INSTALL UPGRADE** button.
- 2 Click the **close** button and continue the configuration process.
- 3 Find the version of SSMA software that is compatible with the sensor's embedded software.

Note

Clicking the **close** button and continuing configuration without upgrading may cause problems with functionality.

Install the firmware upgrade if the SSMA firmware version date is more recent than the sensor's embedded software version date. If the sensor's firmware date is more recent than the SSMA firmware version date, a warning will appear notifying the user that the sensor firmware could be downgraded (see Figure 4.16).



Figure 4.16 - Sensor Firmware Downgrade

The most recent version of SSMA can be obtained from the Wavetronix website (www.wavetronix.com) under the Support tab.

Converting Detection Zones from Previous Software Versions

Previous versions of the SSMA software supported 8 zones. SSMA version 2.0 and later supports 128 zones (8 channels, 4 alerts per channel and 4 zones per alert).

During the firmware upgrade process, SSMA will determine if the sensor is running any previous versions. If this is the case, the SSMA software will display a message asking you to convert the configuration. If you choose to convert the configuration, the SSMA software will create a new configuration out of the previous existing configuration; if you choose NOT to convert, a default configuration will be created.

In this chapter

- General Tab
- Communication Tab

Click the **Sensor Settings** link on the main menu to change and save settings on the sensor.

The Sensor Settings window contains General and Communication tabs (see Figure 5.1).

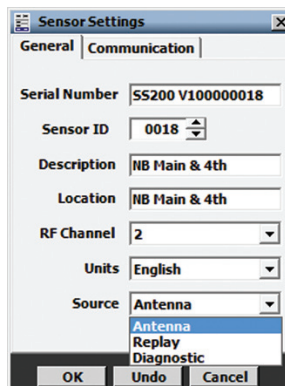

Figure 5.1 - Sensor Settings Screen

General Tab

The General tab contains the following fields (see Figure 5.2):

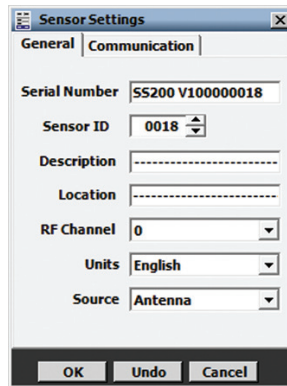

Figure 5.2 – General Tab

- **Serial Number** – Contains the sensor serial number and can only be edited if you are in the Advanced Sensor Setup mode (contact Wavetronix Technical Services for more information).
- **Sensor ID** – Allows you to enter a multi-drop address for the sensor. The ID default is the last four digits of the sensor serial number. The sensor ID can be changed, but no two sensors should have the same ID; the ID must be unique for all sensors on a multi-drop bus.
- **Description** – Allows you to enter a description for each sensor (i.e. its function, application or intended use). Limited to 32 characters.
- **Location** – Allows you to enter the location of the sensor or the approach. Limited to 32 characters.
- **RF Channel** – Displays which radio frequency channel (or non-interference channel) the device is transmitting on. Using multiple SmartSensor Advance devices in close proximity will require each one to be set to a different RF channel. Similarly, using multiple SmartSensor Advance Extended Range devices in close proximity will require each one to be set to a different RF channel. However, a SmartSensor Advance device will not interfere with a SmartSensor Advance Extended Range device, even if they are on the same RF channel. This is because the hardware used to transmit the Digital Wave Radar signal is configured differently on the different devices.
- **Units** – Allows you to display either English (mph/feet) or metric (kph/meters) units.
- **Source** – In normal use, the source is always the radar **Antenna**. However, in some cases, other sources may be used for demonstrations or evaluations. When the source is switched to **Diagnostic**, the antenna is no longer used. Instead, a predetermined sequence of traffic will appear. This setting will always return to **Antenna** after rebooting the sensor.

Communication Tab

The Communication tab is used to specify baud rate and response delay for the sensor's RS-485 ports (see Figure 5.3).

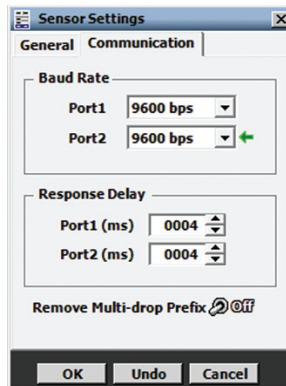

Figure 5.3 – Communication Tab

The Communication tab contains the following settings:

- **Baud Rate** - This section allows you to set the baud rate for ports 1 and 2. The green arrow indicates the communication link (Port) on which SSMA is connected. The default value is 9600 bps.

Note

If you are using a Click communication device, the baud rate for the sensor and the Click device must be the same. Port 2 is designated as the data bus and is normally left at 9600 bps in order to match the default setting on a Click 112/114 card. If you change this baud rate on the sensor, you will also need to change it on the rack card.

- **Response Delay** - This is used to configure how long the sensor will wait before responding to a message received. This is useful for some communications devices that are unable to quickly change transmission direction. The default value is 4 milliseconds for ports 1 and 2.
- **Remove Multi-drop Prefix** - You will only need to turn this switch ON if you are using a device that does NOT support the use of a multi-drop prefix (i.e. Click 100).

Sensor Configuration

In this chapter

- 1. Installation Details
- 2. Automatic Radar Configuration
- 3. Manual Radar Adjustment

The Sensor Configuration screen contains installation details, an automatic configuration feature and manual configuration tools (see Figure 6.1).

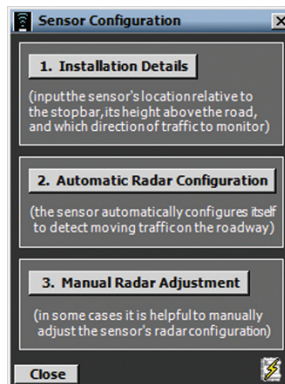

Figure 6.1 – Sensor Configuration Screen

Click the lightning bolt icon on the bottom right corner of the screen to save the current configuration to the sensor's flash memory. The sensor's flash memory is non-volatile memory.

1. Installation Details

The Installation Details screen allows you to position the sensor relative to the stop bar and determine the direction of traffic to be monitored (see Figure 6.2).

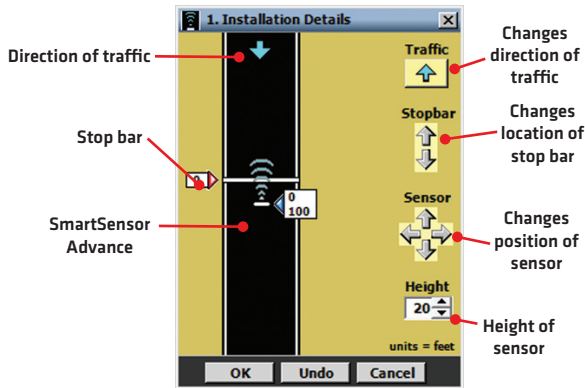

Figure 6.2 – Installation Details Screen

The roadway part of the screen is used to illustrate the sensor's position relative to the stop bar; the controls on the right side of the screen allow you to specify the direction of traffic to be monitored and the sensor's position. The distance units are displayed in the bottom-right corner of the screen.

The **OK** button saves the settings to the sensor; the **Undo** button restores the settings to the screen's initial values; and the **Cancel** button closes the screen without saving changes to the sensor.

Changing the Traffic Direction

The SmartSensor Advance can be configured to detect traffic moving towards or away from the sensor, but will not detect stationary vehicles.

The arrow displayed on the roadway represents the direction of traffic flow being detected by the sensor. Click the **Traffic** button to change the monitored traffic direction. The direction of the arrow displayed on the button shows the direction that will be selected if the button is clicked, and always points in the opposite direction as the arrow on the roadway.

Positioning the Stop Bar

The ability to move the stop bar up and down the display adds flexibility in representing the relative location of the sensor to the stop bar and the direction of traffic flow. The location of the stop bar is always represented as a distance of zero (the sensor range is relative to the stop bar).

Position the stop bar by clicking on the stop bar or its label and dragging it anywhere on

the roadway, or by clicking the **Stop Bar** up/down arrows.

Positioning the Sensor

Position the sensor by clicking on the sensor or its label and dragging it anywhere on the roadway, or by clicking the **Sensor arrow** buttons.

The top number, shown in the sensor position display (next to the blue triangle), represents the sensor's position to the right or left of the center of the lanes being monitored (Cartesian x coordinate); the bottom number represents the sensor's position in front of or behind the stop bar (Cartesian y coordinate), together forming a Cartesian coordinate pair (x, y). The sensor's height is specified by setting the Height value and reflects the sensor's mounting height above the roadway (Cartesian z coordinate).

The resulting (x, y, z) coordinates describe the sensor's position relative to the roadway and are used to translate the sensor's native range measurements to range measurements that are relative to the roadway's frame of reference. The sensor position is also used in the Beam Alignment tool (see Tools).

Note

The sensor's range is updated whenever the stop bar is moved.

Resetting Zones After Sensor Relocation

When the sensor location is changed, existing zones may no longer be within the sensor's detection range and the message below will appear (see Figure 6.3):

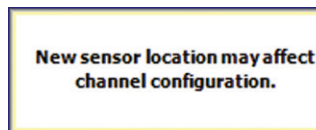

Figure 6.3 - Sensor Location Changed

It is always recommended to first position the sensor and then configure detection zones. However, if the sensor location is modified after zone configuration, you can do one of the following:

- 1 Manually check all detection zones and modify zones as needed (recommended). All zones will still be available and their location relative to the sensor will be preserved. If left uncorrected, the zones may no longer perform the desired detection function.
- 2 Reload only the channel configuration from a backup file created from the existing configuration (the out-of-range zones will be deleted and the desired detection functions may be compromised).

- 3 Reload the individual channel template files used in the current configuration (the out-of-range zones will be deleted and the desired detection functions may be compromised).

2. Automatic Radar Configuration

Click the **Automatic Radar Configuration** button and the Automatic Radar Configuration screen will appear (see Figure 6.4).

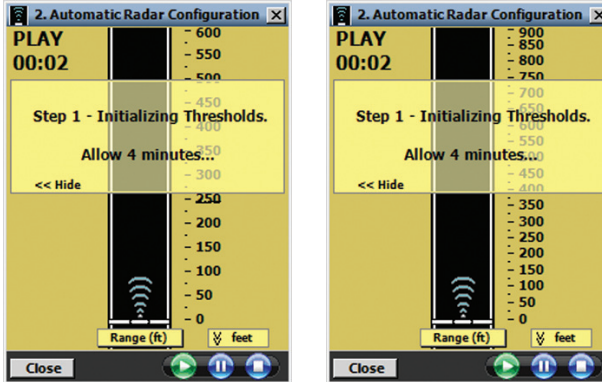

Figure 6.4 – Automatic Radar Configuration Screen for Advance (left) and Advance Extended Range (right)

Note

The ranges displayed in the Automatic Radar Configuration window will depend upon whether you have SmartSensor Advance or SmartSensor Advance Extended Range. The scale on the right side of the road view indicates the ranges.

Click the **Play** button to begin the auto-configuration process. The playing time will be shown in the top-left corner of the screen. After approximately three minutes, trackers (sensor detections) will begin to appear on the roadway and the process will change to Step 2 Adjusting Thresholds. The **Pause** button pauses the auto-configuration process; the **Stop** button will terminate auto-configuration. The **Close** button closes the screen and returns to the Sensor Configuration job menu. If the configuration process is running, it will continue to run after closing. To terminate the automatic radar configuration process, press the **Stop** button.

The semi-transparent message window can be toggled on/off by clicking the **Show>>** and **<<Hide** labels. The roadway range scale can be toggled on/off by clicking the feet label.

The following is a list of tracker display data that can be viewed by clicking the Range (ft) display bar at the base of the roadway:

- **Range** - Shows the distance from the stop bar.
- **Speed** - Shows the speed.
- **Estimated Time of Arrival** - Shows the estimated time it will take to arrive at the stop bar.
- **Tracker ID** - Shows the ID number for each tracker.
- **Blank** - (no tracker data shown)
- **Disabled** - (no tracker data shown)

3. Manual Radar Adjustment

The Manual Radar Adjustment screen is used to fine-tune the results of the automatic radar configuration process (see Figure 6.5).

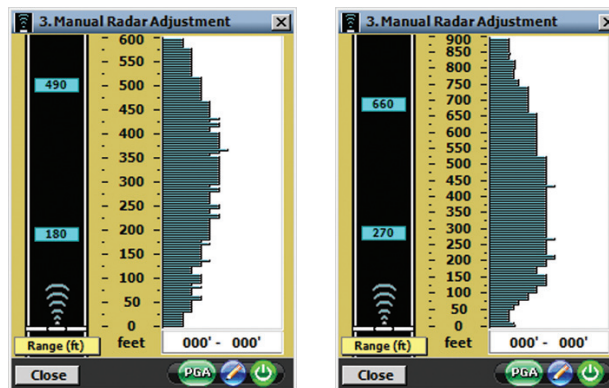

Figure 6.5 - Manual Radar Adjustment Screen for Advance (left) and Advance Extended Range (right)

Note

The ranges displayed in the Manual Radar Adjustment window will depend upon whether you have SmartSensor Advance or SmartSensor Advance Extended Range. The scale on the right side of the road view indicates the ranges. The SmartSensor Advance has 5-ft increments up to 600 ft, and the SmartSensor Advance Extended Range has 7.5-ft increments up to 900 ft.

You will notice in the button tray at the bottom of the window (see Figure 6.5) there is a **Reboot** button (green power button icon). When you press this button it will tell you that the reboot may take up to 20 seconds (see Figure 6.6).



Figure 6.6 – Reboot

If you were in the process of manually editing detection thresholds, it will ask you if you would like to save these changes to the sensor's flash before rebooting (see Figure 6.7). If you do not save these changes they will be discarded.

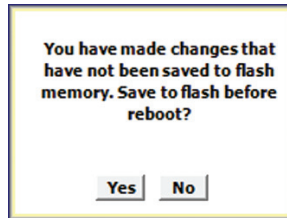

Figure 6.7 – Save Changes

During the reboot time, the power button will turn red (see Figure 6.8), but once the sensor has rebooted it will go back to green again.

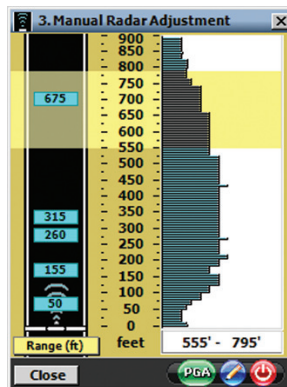

Figure 6.8 – Red Button During Reboot

Editing Sensitivity

If missed detections are consistently noticed, the sensor's sensitivity can be adjusted. Decreasing the detection threshold levels in areas where trackers begin to disappear will reduce the number of missed detections. To increase the sensor's sensitivity, decrease the detection threshold levels; to decrease the sensor's sensitivity, increase the detection threshold levels.

Note

Do not reduce the thresholds so low that “phantom detections,” or false detections in the absence of traffic, begin to appear.

If phantom detections are consistently visible, increase the sensor’s detection thresholds in these areas. Phantom detections can occur if large objects in the sensor’s field of view move faster than 1 mph (2 kph). If the thresholds are too low, the sensor can pick up trees swaying in strong winds or fast-moving pedestrians.

Double detections from vehicles such as double-bed trailers are not considered false detections. It is often beneficial for the sensor to signal an actuated traffic controller based on both detections. In cases of double detections, the thresholds will not need to be increased.

Follow the steps below to adjust the sensitivity:

- 1 Determine the ranges for which detections need to be adjusted.
- 2 Click and drag to select the section of the histogram (range bins) that needs to be adjusted (see Figure 6.9).

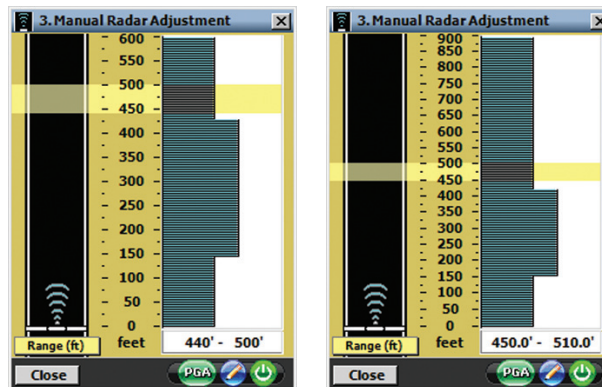

Figure 6.9 – Editing Ranges for Advance (left) and Advance Extended Range (right)

Note

The ranges displayed in the manual radar configuration view will depend upon whether you have SmartSensor Advance or SmartSensor Advance Extended Range. The scale between the road view and the threshold histogram bars indicates the ranges. With SmartSensor Advance each threshold is every 5 feet. With SmartSensor Advance Extended Range each threshold is every 7.5 feet.

- 3 Click the **Edit** button and the Edit Sensitivity Thresholds screen will appear (see Figure 6.10). The following three editing modes are available for modifying sensitivity values:
- The +/- mode adds or subtracts the specified number to the existing sensitivity levels.
 - The % mode sets the sensitivity level to be the specified percent of the existing value.
 - The **Value** mode sets the sensitivity level to be the specified value.

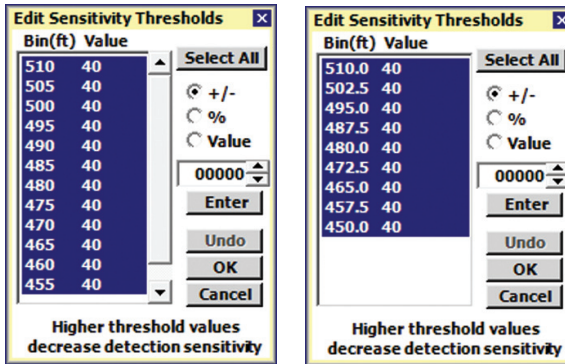

Figure 6.10 – Edit Sensitivity Thresholds Screen for Advance (left) and Advance Extended Range (right)

- 4 Click and drag again to select the exact range bins to adjust.
- 5 Make the sensitivity level adjustments.
- 6 After adjusting the sensitivity, click the **Enter** button to apply the adjustment.
- 7 Click the **OK** button to accept the modifications and close the Edit Sensitivity window; click the **Undo** button to return all modified sensitivity levels to their initial values; or click the **Cancel** button to undo all changes made.
- 8 Re-evaluate the detections.

If any changes were made during the Sensor Configuration process, a pop-up window will appear prompting the user to save the changes to the sensor's FLASH memory. Changes that were not written to FLASH will be lost the next time the sensor reboots. The process of saving to FLASH memory takes approximately five seconds.

Selecting a Tracker Display Mode

The following is a list of tracker display data that can be changed by clicking the display bar at the base of the roadway:

- Range
- Speed
- ETA
- ID
- Blank
- Disabled

Changing the PGA

The Programmable Gain Amplifier (PGA) allows you to change the radar sensitivity for the entire approach (see Figure 6.11).

Note

Consult with Wavetronix Technical Services before changing the PGA setting.

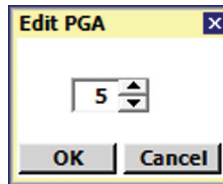

Figure 6.11 - Editing the PGA

Channels-Alerts-Zones

In this chapter

- Channels
- Alerts
- Zones

The Channels-Alerts-Zones (CAZ) screen allows you to set up and verify channels, alerts and zones; set up output communications; and import/create a template (see Figure 7.1).

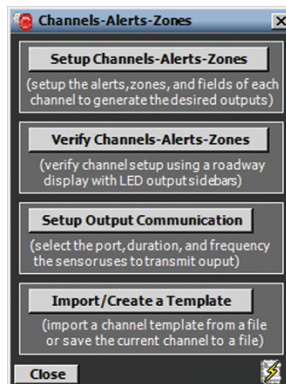

Figure 7.1 – Channels-Alerts-Zones Screen

This chapter will explain the different types of channels and how they are mapped to alerts and zones.

The CAZ Setup screen provides configuration access to all CAZ elements.

Channels

The channel is the highest-level detection unit. The user-defined channel name, used to distinguish one channel from another, can consist of eight ASCII characters. The channel number (1–8) is used to associate sensor channels with Click contact closure channels.

The **Type** drop-down list allows you change the channel type from the default type. For SmartSensor Advance Extended Range, the default channel type is **Priority** for channels 1–3 and **Simple** for channels 4–8. For SmartSensor Advance, the default type is **Simple** for all channels. SmartSensor Advance does not have **Priority** channels, but both sensors have two additional types of channels: **Normal** and **Latched** (see Figure 7.2).

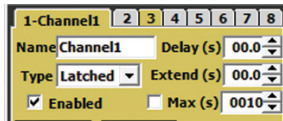

Figure 7.2 – Channel Configuration

The channel configuration is read from the sensor the first time that the CAZ job is selected. Due to the amount of information represented in the configuration, the retrieval may take five seconds or more, depending on the speed and quality of the connection.

Note

The channel output from a sensor is usually tied to a channel input in a controller.

Click the **Enabled** checkbox and all channel features will become available. When a channel is enabled, the channel portion of the setup screen and its associated tab is colored gold; when a channel is disabled, the channel section is gray.

Simple Channel

A simple channel consists of one dedicated zone, which is a lower-level detection unit. The simple channel provides an easy and quick way to set up the zone (see Figure 7.3).

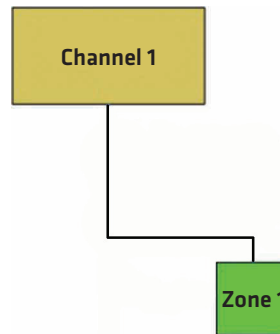

Figure 7.3 - Simple Channel Hierarchy

To create a simple channel, select **Simple** from the **Type** drop-down menu and the following screen will appear (see Figure 7.4):

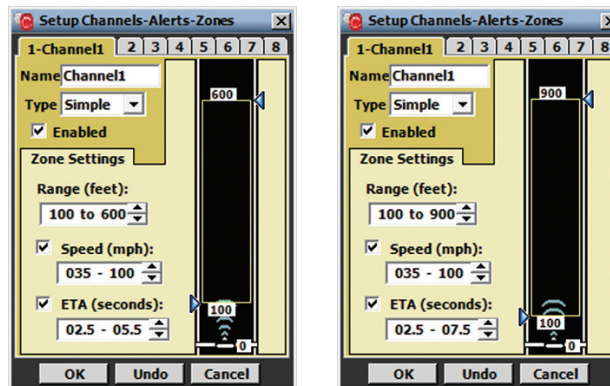

Figure 7.4 - Simple Channel for Advance (left) and Advance Extended Range (right)

A simple channel allows you to configure the most basic zone settings. You can change the size of the zone by either clicking and dragging the zone arrows anywhere along the roadway or by using the up/down arrows in the **Range (feet):** field.

You can set the **Speed** and **ETA** settings by first clicking the **Speed/ETA** checkbox and then setting the parameters using the up/down arrows. Click **OK** to save the changes you make to each channel.

Note

Make sure that the **Speed/ETA** checkboxes are checked before you click **OK**. If the checkboxes are not checked, those settings will NOT be enabled.

The SmartSensor Advance is most commonly used with advance detection at signalized

intersections. A very powerful method of advance detection uses two simple channels: Advance and QReduce.

The Advance channel provides green extension at high-speeds for safety and efficiency. The QReduce channel provides green extension at low-speeds when the initial queue is dissipating.

Follow the steps below to configure the Advance channel:

- 1 Click on **Channels-Alerts-Zones** on the main menu.
- 2 Click the **Setup Channels-Alerts-Zones** button.
- 3 Enable a channel by checking the **Enabled** checkbox.
- 4 Select **Simple** from the **Type** drop down list.
- 5 Adjust the size of the zone by either using the **Range (feet)**: up/down arrows or by manually grabbing the zone's blue arrows and dragging them anywhere on the roadway.
- 6 Click the **Speed** and **ETA** checkboxes to activate the Speed and ETA parameters.
- 7 Set the speeds from 35 mph on low end to 100 mph on high end.
- 8 Name the channel "Advance" and click **OK** to save the channel settings.

Follow the steps below to configure the QReduce channel:

- 1 Click the second tab on the top of the Setup Channels-Alerts-Zones screen.
- 2 Enable the channel by clicking the **Enabled** checkbox.
- 3 Select **Simple** from the **Type** drop-down list.
- 4 Adjust the size of the zone to 100 to 150 feet from the stop bar.
- 5 Click the **Speed** checkbox to activate this filter and select speeds from 1 to 35 mph.
- 6 Name the channel "QReduce" and click **OK** to save the channel settings.

The **OK**, **Undo** and **Cancel** buttons pertain to ALL changes made in the CAZ Setup job and not to individual channels, alerts or zones. The **OK** button saves the settings to the sensor; the **Undo** button restores the settings to the screen's initial values; and the **Cancel** button closes the screen without saving any changes.

Priority Channel

A priority channel consists of three zones, each with a complementary role (see Figure 7.5). When any one of the three zones is active, the channel output is active (equivalent to a Boolean OR of the three zone outputs).

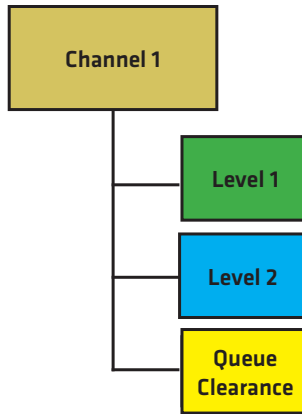

Figure 7.5 – Priority Channel Zones

The first two zones work in tandem to allow you to provide different levels of dilemma zone protection based upon the discovery range of each vehicle. Vehicles discovered upstream of the discovery range threshold are classified as level one priority and are given the highest level of protection. Vehicles discovered downstream of the discovery range threshold are classified as level two priority and are given a reduced but adequate level of protection.

Note

Priority channels are only available with SmartSensor Advance Extended Range. The extended range of the sensor is best matched to:

- Distinguish between large vehicles (trucks and buses) and small vehicles (passenger cars).
- Provide dilemma zone protection for large vehicles. Trucks have been shown to have dilemma zones a far back as 7.5 seconds. For example, an ETA of 7.5 seconds at 65 mph is equivalent to 715 ft. (217.9 m). This is beyond the range of SmartSensor Advance, but not SmartSensor Advance Extended Range.

By default the discovery range threshold is set at 750 feet. If necessary, adjust the discovery range threshold so that most large vehicles are discovered beyond this threshold and most small vehicles are discovered after it.

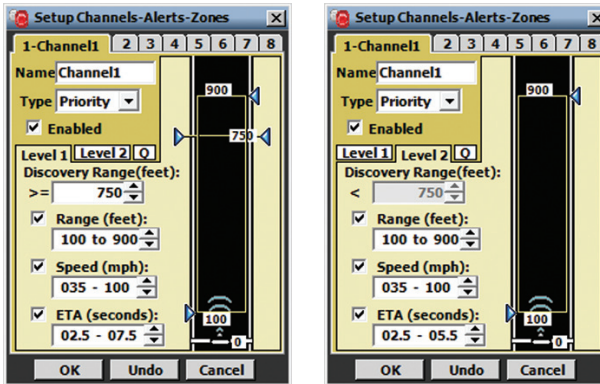

Figure 7.6 – Setup Channels-Alerts-Zones Screen for Priority Channel

The level-one zone will activate the channel output when a level-one priority vehicle meets the specified criteria. By default the ETAs protected are between 2.5 and 7.5 seconds because trucks and other large vehicles have been found to have a larger dilemma zone.

The level-two zone will activate the channel output when a level-two priority meets the specified criteria. By default the ETAs protected are between 2.5 and 5.5 seconds because passenger cars and other light-duty vehicles have been found to have a smaller dilemma zone.

The third zone is a queue-clearance zone. This zone activates the channel output when the initial queue of traffic is dissipating at low speeds. It is recommended that all three zones be used in combination with 1.0 seconds of passage time in the controller.

For the queue clearance zone, a 1.0 passage time is added to the maximum time headway between two vehicles occupying the zone at the same time to determine the maximum allowable time headway. When the zone is 50-foot wide and the vehicles are 20-foot long, the maximum time headway between two vehicles occupying the zone at the same time at 30 mph is approximately 1.6 seconds. After adding 1.0 seconds of passage time, maximum allowable headway for 30 mph vehicles becomes 2.6 seconds. Slower vehicles will experience a large maximum allowable headway, which is useful during the startup period of queue dissipation in order to avoid gap out.

If you need to increase the maximum allowable headway you can increase the size of the queue clearance zone, or the passage time. Normally it is recommended to keep the passage time small and increase the size of the queue clearance zone. This is because the size of the queue clearance zone will not matter when the flow speeds are above 35 mph, and because you want to keep the passage time trim when trying to find a safe gap in high-speed traffic.

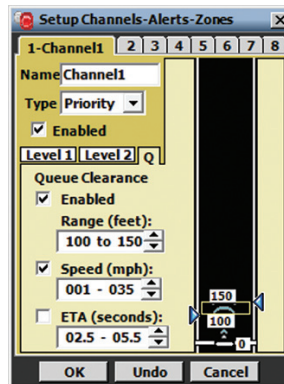

Figure 7.7 – Providing Dilemma Zone Protection

By providing zones for level-one priority dilemma zone protection, level-two dilemma zone protection and queue clearance, a priority channel provides exceptional detection from start-of-green to end-of-green.

Note

There may be a number of uses of the discovery range feature for other applications than truck priority. For example, you could require that a vehicle be discovered at a certain range (using the discovery range threshold) and that it travels to a downstream zone several hundred feet away before it activates a channel output. This is a way to know that we have tracked a specific vehicle over an extended range. This is better than simple using the channel delay because it isolates a single vehicle.

Normal Channel

Normal channels consist of (see Figure 7.8):

- 8 channels
- 4 alerts per channel (32 total)
- 4 zones per alert (128 total)

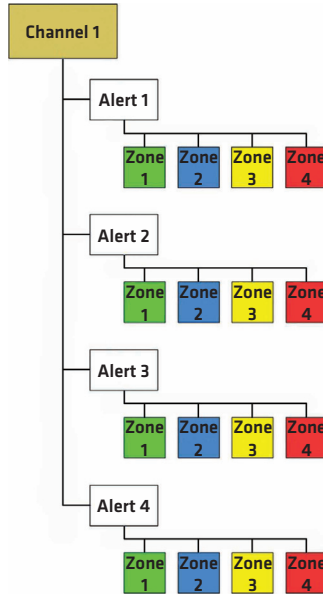

Figure 7.8 – Normal Channel Hierarchy

The CAZ Setup screen below shows a tabbed view of each detection channel and its associated alerts and zones (see Figure 7.9). The eight tabs at the top of the screen represent the sensor’s eight channels, with the selected tab showing the channel number and channel name; the middle portion of the screen contains alert configuration parameters; and the lower portion of the screen contains zone configuration parameters.

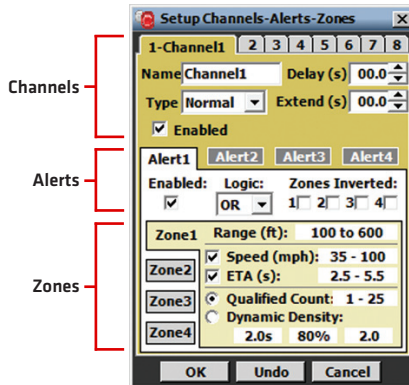

Figure 7.9 – Setup Channels-Alerts-Zones Screen

The **OK**, **Undo** and **Cancel** buttons pertain to ALL changes made in the CAZ Setup job and not to individual channels, alerts or zones. The **OK** button saves the settings to the sensor; the **Undo** button restores the settings to the screen’s initial values; and the **Cancel** button closes the screen without saving any changes.

Normal channels consist of four alerts, each containing four zones. A normal channel's output is a logical combination of the channel's alert, zone, delay and extend settings (see Delay and Extend sections under Latched Channels). The normal channel's output becomes active when the associated alert and zone logic, the channel delay or the channel extend are satisfied.

Each enabled normal channel must have at least one enabled alert. If you attempt to save an invalid channel configuration, the following message is displayed (see Figure 7.10).

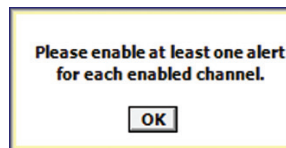

Figure 7.10 – Invalid Channel Configuration

Latched Channel

Latched channels consist of two alerts (ON and OFF), each containing up to four zones (see Figure 7.11). A latched channel, by definition, has exactly two enabled alerts that cannot be disabled.

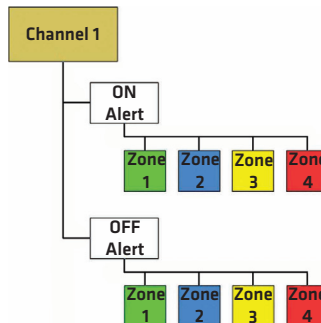

Figure 7.11 – Latched Channel Hierarchy

Latched channels differ from normal channels in that the channel output remains in a given state until a contradictory alert is exclusively activated, or a maximum latch time has expired (see Figure 7.12).

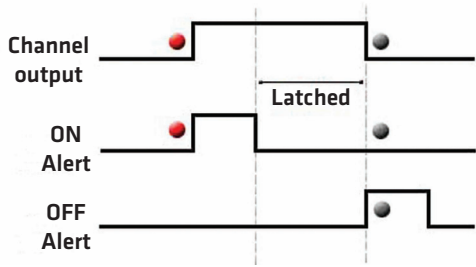

Figure 7.12 - Latched Channels

For example, a channel’s output will become activated when an ON alert is triggered and will latch (stay active) even when the ON alert is no longer triggered. Subsequently, if an OFF alert is triggered, the channel output will be deactivated as soon as all other timing conditions are satisfied (e.g. the minimum ON time, channel extend).

Note

When changing a normal channel to a latched channel, alerts 1 and 2 will be used as the ON and OFF alerts, respectively (alerts 3 and 4 will be disabled).

Delay

The channel delay is used to ignore alert outputs that are shorter than the specified delay time (see Figure 7.13). Latched channels do not activate outputs until the delay requirements have been met (only a channel’s alert and zone logic are applied during the delay period).

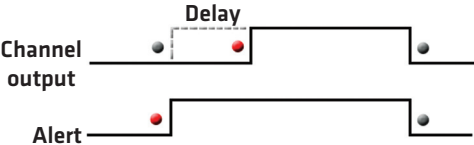

Figure 7.13 - Channel Delay

Extend

The extend feature is used to continue a channel output after the required conditions have been met (see Figure 7.14). For example, if a vehicle enters a zone and activates the channel output, that channel would remain ON for a specified extend time after the vehicle leaves the zone.

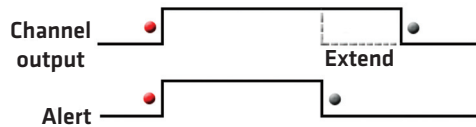

Figure 7.14 - Channel Extend

Max (s)

The channel Maximum Latch Timer is used to turn a latched channel off after it has existed continuously in a latched state for a specified period of time. The latch timer, labeled Max (s), is available only when using latched channels and can be enabled/disabled by checking/unchecking the checkbox next to the Max (s) label.

If enabled, the latch timer specifies how long a latched channel may operate continuously in the latched state. In a case where the OFF condition was not detected, the latch timer can be used to prevent a latched channel from remaining indefinitely (and unintentionally) in the ON state.

The latch timer can also be used to generate a latched output of specified duration. This timed output can be achieved by defining the OFF alert to have a configuration that is not likely (essentially impossible) to be activated.

Note

A latched channel may have its output activated indefinitely (even if the latch timer is enabled), if the ON alert is never turned off or if it is repeatedly turned off and on before the latch timer expires.

A latched channel with an impossible OFF alert could be used to drive an over-speed beacon or any other type of ancillary signal that is based on the activating of the ON alert and whose indication has a fixed duration.

Note

The extend period occurs after the latched condition is terminated. This means that the output will remain activated, after the latch timer expires, for an additional period of time (as specified by the extend setting).

Alerts

The alert is the mid-level detection unit and is used to define the corresponding channel's output (see Figure 7.15).



Figure 7.15 – Alert Configuration

Enabling an Alert

When an alert is enabled, the alert section of the setup screen turns white; when an alert is disabled, the alert section turns dark gray. A normal channel contains alerts 1 through 4 and a latched channel contains an ON alert and OFF alert that cannot be disabled.

Each enabled alert must have at least one enabled zone. If you attempt to save an invalid alert configuration, a prompt will appear asking you to activate one zone for each enabled alert.

Logic (OR/AND)

An alert's logic setting specifies the Boolean logic operation to be applied to the alert's zone outputs. The available options are OR and AND. If OR logic is selected, the alert will turn ON if one or more zones have active outputs; if AND logic is selected, the alert will turn ON only if ALL enabled zones have active outputs.

Inverted Zones

In order to provide more flexibility, an alert can invert a given zone's output BEFORE applying the alert's specified logic operator on the zone outputs.

For example, if an alert has only one enabled zone (zone1), and that zone's output is OFF (did not find a qualified detection in the zone), then the alert's output will be OFF. However, if the alert were configured to invert the zone's output, then when the zone's output is OFF, the alert's output will be ON.

Zones

The zone is the lowest-level detection unit. A zone's output is used to define the corresponding alert's output.

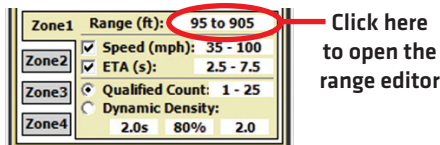

Figure 7.16 – Zone Configuration

Below is a description of each parameter in the zone section of the CAZ Setup screen (see Figure 7.16).

Range (ft)

A zone is enabled when its range is defined. When a zone is enabled, the zone section of the setup screen turns yellow; when a zone is disabled, the zone section turns light gray. A detection must be within a zone's range limits in order to activate that zone's output. All zone ranges in a given alert are configured in a single screen and may not overlap in range. Click in the zone range display next to the range label to open the zone range editor (see Figure 7.17).

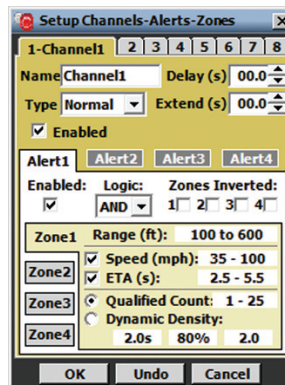

Figure 7.17 – Zone Range Editor

To add (enable) a zone, drag the desired zone icon from the zone well to the roadway; to remove (disable) a zone, drag it from the roadway to the zone well (or anywhere off the roadway). If a zone is moved to an invalid location, it will be returned to its previous location.

To change the range of a zone, drag the blue triangle markers up or down the roadway or click the up/down arrows on either side of the screen (see Figure 7.18). The zone can be placed anywhere on the roadway by clicking anywhere inside the zone and dragging it. The minimum range is 50 ft. (15.2 m) from the sensor and the maximum range is 600 ft. (152.4 m) from the sensor.

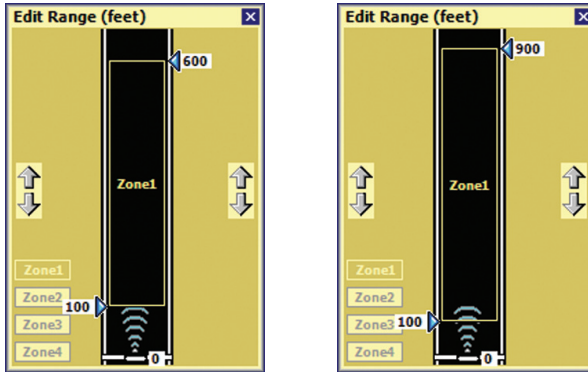

Figure 7.18 – Adjusting Zones for Advance (left) and Advance Extended Range (right)

Speed (mph) and ETA (s)

In addition to range, zone detections can also be filtered by speed and by the estimated time of arrival to the stop bar. Click anywhere in the Speed or ETA area and the Edit Basic Filters screen will appear (see Figure 7.19).

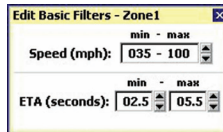

Figure 7.19 – Edit Basic Filters Screen

Edit the min and max values in the speed filter to set the range of qualified speeds. The minimum speed value is 1 mph (2 kph) and the maximum speed value is 100 mph (161 kph).

On the previous window, check the box to the left of the Speed label to enable the speed filter (only speeds within the range will activate zone outputs); uncheck the box to disable the speed filter (all speeds will activate zone outputs).

Edit the min and max values in the ETA filter to set the range of qualified ETAs. The minimum ETA value is 0.1 seconds and the maximum ETA value is 25.4 seconds. If you try to raise the max ETA value above 25.4, the filter will be set to INF, which will accept any vehicle with an estimated time of arrival greater than the minimum.

On the previous window, check the box to the left of the ETA label to enable the ETA filter (only ETAs within the range will activate zone outputs); uncheck the box to disable the ETA filter (all ETAs will activate zone outputs).

Qualified Count

A qualified detection is a detection in a zone that meets the specified range, speed and ETA

filters. The SmartSensor Advance provides two very powerful detection qualification filters: Qualified Count and Dynamic Density™. These filters are mutually exclusive (only one may be active at a time).

The qualified count filter is used to limit a zone's outputs to times when there are a certain number of qualified detections in the zone at one time.

Click in the Qualified Count range and the Edit Qualified Count filter will appear. Edit the min and max values to set the qualified count range (see Figure 7.20). Only qualified detections within the set range will activate zone outputs. The minimum qualified count value is 1 and the maximum qualified count value is 25.

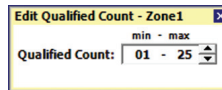

Figure 7.20 – Qualified Count Filter

Click the radio button to the left of the Qualified Count label to enable the qualified count filter.

Dynamic Density

Dynamic Density is a type of vehicle platoon detection that activates a zone's output when the number of qualified detections within a zone equals or exceeds a density requirement. The following equations explain the density requirement formula, called the Dynamic Density Count Requirement (DDCR).

First, traffic density is defined as the number of vehicles within a zone, divided by the area of the zone (see Figure 7.21).

$$\text{Density} = \frac{\text{Number of Vehicles in a Zone}}{\text{Zone Size (ft.)} \times \text{Lane Tuning Factor}}$$

Figure 7.21 – Required Density Equation

To maintain a given level of efficiency, the required density increases as speeds decrease; similarly, the required density decreases as speeds increase. Therefore, to achieve a Required Flow Rate, the density of traffic will dynamically change with the speed of the vehicles as shown in Figure 7.22.

$$\text{Density} = \frac{\text{Required Flow Rate}}{\text{Speed}}$$

Figure 7.22 – Flow Rate Equation

In addition, the Required Flow Rate is equal to the ideal flow rate multiplied by the required % Utilization. Since ideal flow rate is inversely proportional to the ideal time Head-

way between vehicles, this can be written as show in Figure 7.23.

$$\frac{\text{Required Flow Rate}}{\text{Ideal Flow Rate}} = \%Utilization = \frac{\%Utilization}{\text{Time Headway}}$$

Figure 7.23 – Equation for Dynamic Density Vehicle Count Threshold

Consequently, the Dynamic Density Count Requirement (DDCR) calculated by the Dynamic Density filter is computed as shown in Figure 7.24.

$$\text{Dynamic Density Count Requirement (DDCR)} = \text{Round} \left[\frac{\%Utilization \times \text{Lane Tuning Factor} \times \text{Zone Size}}{\text{Time Headway} \times \text{Instantaneous Mean Speed in Zone}} \right]$$

Figure 7.24 – Dynamic Density Count Requirement Equation

If the number of qualified detections is equal to or greater than the DDCR, then the Dynamic Density requirement has been satisfied and the zone output will be activated.

Table 7.1 below reviews the components of the Dynamic Density filter. The number of qualified detections and their average speed is detected by the sensor. Then based upon values of Zone Size, % Utilization, Tuning Factor, and headway parameters entered by the user, the DDCR will be calculated and the zone output determined.

	Component	Description
Detected by the Sensor	Qualified Count	The number of vehicles that meet a zone's range, speed and ETA filters.
	Speed	The average speed of all qualified detections in the specified zone, as calculated by the sensor (ft per second).
Entered by the User	Zone Size	The length of the specified zone (ft.).
	%Utilization	Specified by the user (%).
	Tuning Factor	Specified by the user.
	Headway	Specified by the user (seconds per vehicle).

Table 7.1 – Description of Dynamic Density Equation

Click in the display area beneath the Dynamic Density label to edit the Dynamic Density filter (see Figure 7.25).

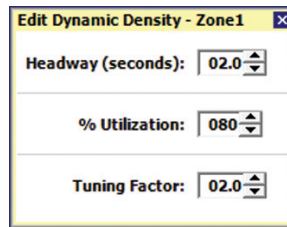

Edit Dynamic Density - Zone1	
Headway (seconds):	02.0
% Utilization:	080
Tuning Factor:	02.0

Figure 7.25 – Dynamic Density Filter

Dynamic Density allows the SS200 to generate outputs based on traffic efficiency. The three filter elements (Headway, % Utilization, and Tuning Factor) are combined with the size of the zone and the average speed of qualified detections to create a detection density threshold that changes with the fluctuations in detected traffic.

Headway refers to the time separation of the front edge of two consecutive vehicles traveling in a given lane. The headway metric is inversely proportional to the flow rate of a given lane and is widely used as a measure of how efficiently traffic is flowing in a given lane.

A typical headway value for heavily traveled lanes is two seconds, which corresponds to a flow rate of 1800 vehicles per hour. In the Dynamic Density settings, the minimum headway value is 0.1 seconds and the maximum headway value is 10.0 seconds.

% Utilization refers to the ratio of observed flow rate to ideal flow rate. It is a measure used to describe traffic efficiency in terms of the ideal efficiency. In the Dynamic Density settings, the minimum utilization value is one percent and the maximum utilization value is 100 percent.

Note

Consider a case where a lane is operating at the lower bounds of acceptable efficiency when only 75 percent of its ideal flow rate was realized. If the ideal flow rate were 1800 vehicles per hour, then the lane is being used adequately at a flow rate of $0.75 * 1800 \text{ vehicles/hour} = 1350 \text{ vehicles/hour}$ (or a headway of 2.67 seconds).

The Tuning Factor is a general-purpose scale factor used to adjust observed results to represent actual road conditions. The tuning factor resides in the numerator of the Dynamic Density equation. The initial recommendation for the tuning factor value is to set it equal to the number of lanes being observed by the sensor. The minimum tuning value is 0.1 and the maximum tuning value is 10.0.

Verify Channels-Alerts-Zones

In this chapter

- Right Sidebar
- Left Sidebar
- Tracker Highlighting

The Verify Channels-Alerts-Zones screen contains both configuration and detection information (see Figure 8.1).

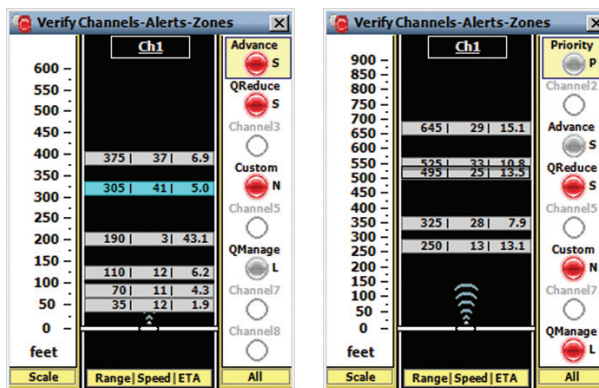

Figure 8.1 - Verify CAZ Screen for Advance (left) and Advance Extended Range (right)

Note

When verifying channels, alerts and zones, you can use the range scale to help identify whether you have SmartSensor Advance or SmartSensor Advance Extended Range.

This chapter will explain the different views and capabilities of the Verify Channels–Alerts–Zones screen. The main sections of the screen (the right sidebar, the left sidebar and the roadway display) will allow you to verify that the SmartSensor Advance is functioning correctly.

Note

Simple channels are shown on the right side bar with the letter “S” next to the channel LED; latched channels are shown with the letter “L.”

Right Sidebar

The right sidebar is designed to show detections and summarize configuration settings for all channels, alerts and zones (see Figure 8.2). A channel must be enabled in order to be included in the list of individual channels that can be verified.

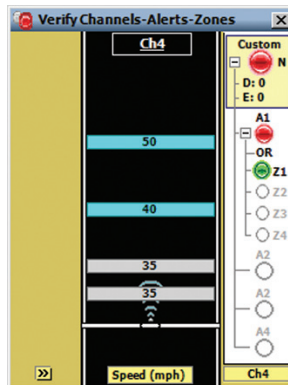

Figure 8.2 – Right Sidebar

The right sidebar also allows you to select which CAZ element is highlighted in the roadway and displays the corresponding outputs of each configured CAZ element (see Table 8.1).

Outputs	ON Color	OFF Color	Disabled Color
Channel	Red	Gray	Blank
Alert	Red		
Zone 1	Green		
Zone 2	Blue		
Zone 3	Yellow		
Zone 4	Red		

Table 8.1 – Right Sidebar Output Colors

Click and hold the right sidebar display button to access the display mode list (see Figure 8.3).

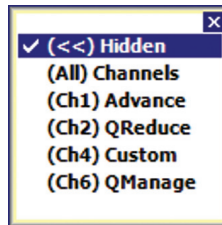

Figure 8.3 – Right Sidebar Display Mode List

Hidden

The hidden view hides the right sidebar and is used to simplify the overall appearance of the verification screen.

(All) Channels

The (All Channels) view shows an LED for each of the SmartSensor Advance’s eight channel outputs. The channel outputs are transmitted to a contact closure device, which in turn generates an appropriate signal on the corresponding contact closure output channels.

The channel LED is colored red when a given channel’s output is activated. The channel LEDs also show the effects of the channel’s delay and extend settings.

To identify which detections are affecting the channel’s output, click on the channel output you want to identify (see Figure 8.4). If a detection meets the selected channel’s alert and zone filter settings, the tracker will be highlighted light blue.

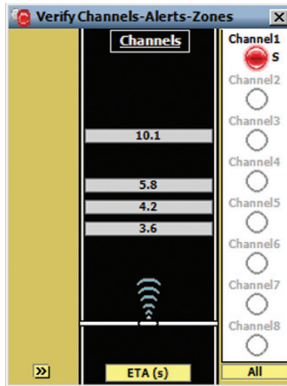

Figure 8.4 – All Channels Mode

Tip

Click and hold on a channel LED to open the individual channel summary screen. The channel summary screen shows the channel type, delay and extend settings and all enabled alerts for that channel.

Individual Channel

The individual channel view allows you to see the CAZ elements defined for a given channel (see Figure 8.5).

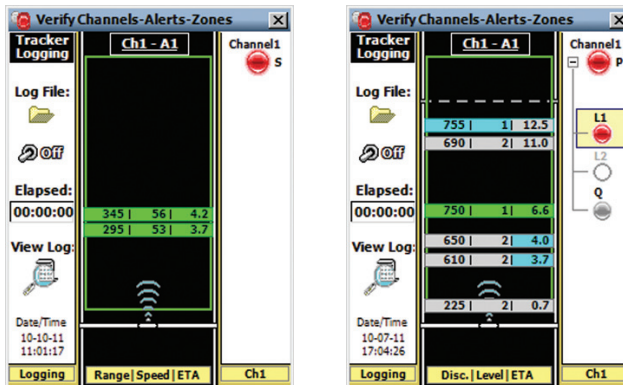

Figure 8.5 – Individual Channel View (Simple Channel) for Advance (left) and Priority Channel for Advance Extended Range (right)

Note

In Figure 8.5 the dashed, gray line near the top of the zone is used to indicate the location of the discovery range threshold for this priority channel. Vehicles first discovered before the discovery range threshold will be highlighted when viewing at the Level 1 alert and will also have a priority level of one when shown on the roadway. Vehicles first discovered after the discovery range threshold will be highlighted when viewing at the Level 2 alert and will also have a priority level of two when shown on the roadway.

Simple channels (annotated with an S) show only the channel output in the right-side bar, and priority channels (annotated with a P) go one layer deeper to the alert level. Because a priority channel only has one zone for each alert, only the alert level is shown. The normal channel (annotated with an N) and latched channel (L) go further down to the zone level (see Figure 8.6).

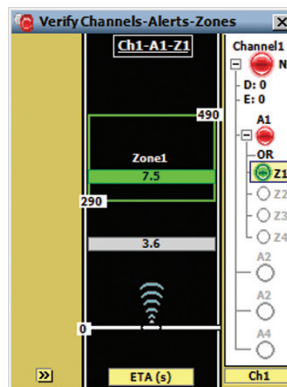

Figure 8.6 – Individual Channel View (Normal Channel)

A zone output is activated when its detection qualification filters are satisfied; an alert output is activated when the associated zone outputs fulfill the alert's logic filter; and a channel output is activated when the associated alert outputs (and related delay and extend settings) fulfill the channel's requirements.

Note

Only channel outputs are reported to contact closure devices. While they are reported to SSMA, zone and alert outputs are not directly associated with any contact closure outputs.

The channel name is displayed above the channel LED. Latched channels display an L

next to the channel LED (see Figure 8.7). A channel's delay, extend and max timer settings are shown next to the D:, E: and M: labels under the channel LED. An alert identifier is displayed above each alert LED; the alert logic indicator (OR/AND) is located beneath each alert LED. Only one alert can be expanded at a time.

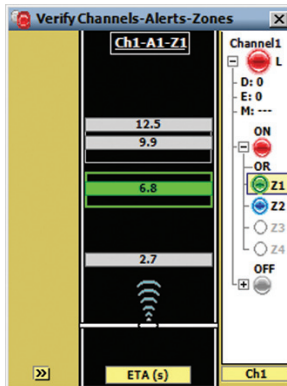

Figure 8.7 – Individual Channel View (Latched Channel)

A zone label (Z1, Z2, Z3, Z4) is displayed to the right of each zone LED. If an alert has an inverted zone, a logical NOT marker (solid black line) is displayed above the associated zone label.

Tip

Click and hold on the alert LED to view the Alert Summary screen. The top of the Alert Summary screen shows the channel that the alert belongs to. The rest of the screen shows the logic applied to the alert, which zones are enabled and which zones are inverted (if any).

Click and hold on the Zone LED to view the Zone Summary screen. The top of the Zone Summary screen shows the channel and alert that the zone belongs to; the rest of the screen shows the zone's Range, Speed, ETA and Qualified Count settings for the selected zone.

Channel LED

The channel LED is colored red whenever a channel's output requirements are met (see the Display Mode section). When a channel is selected, trackers are highlighted in light blue if they meet any of the selected channel's zone filters (see Figure 8.8). This form of tracker highlighting helps you know which detections are affecting the channel's output.

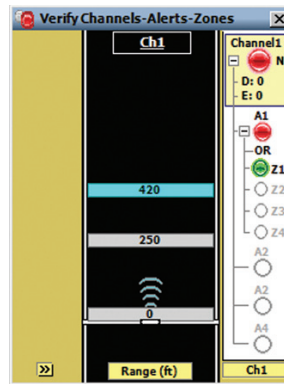

Figure 8.8 – Channel LED

Alert LED

The alert LED is colored red when an alert's output requirements are met (see Figure 8.9). If an alert is selected, the corresponding zones will appear on the roadway, each with a unique color.

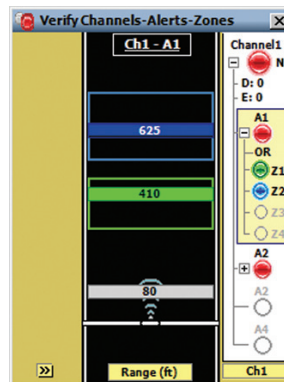

Figure 8.9 – Alert LED

Zone LED

Each of the four available zones show a different color. This color mapping between zone rectangles, trackers and zone LEDs shows how trackers affect zone outputs (see Table 8.2).

Zone	Color
1	Green
2	Blue
3	Yellow
4	Red

Table 8.2 – Zone Colors

When an alert is selected, the alert's enabled zones are displayed on the roadway. The other enabled zones in the corresponding alert are shown as gray rectangles (see Figure 8.10). When a zone's detection qualification requirements are met (or NOT met, if the zone output is being inverted), the corresponding zone LED is colored its corresponding zone color.

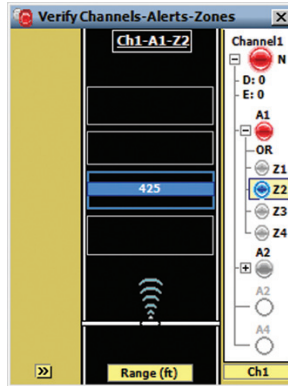

Figure 8.10 – Zone Highlighting

Note

Tracker highlight behavior is determined by the selected roadway display mode.

Roadway Display

The roadway display is used to show trackers and their relationship with detection zones (see Figure 8.11).

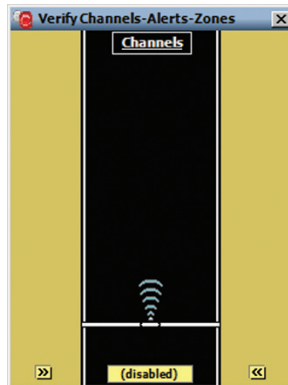

Figure 8.11 – Roadway Display

The area between the sensor icon and the top part of the roadway display represents the

sensor's maximum detection range. The sensor icon is always displayed at the bottom of the roadway and points towards the top of the screen. Sensor detections (trackers) are displayed on the roadway in relation to their distance from the stop bar.

The CAZ selection display is located on the top of the roadway and contains the currently selected channel, alert and zone (see Figure 8.12).

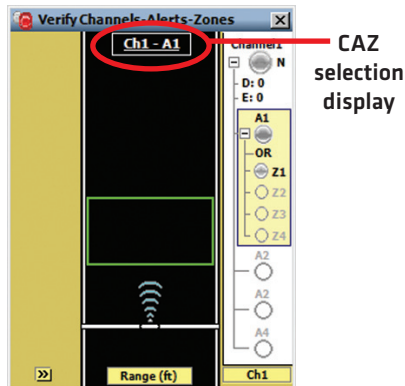

Figure 8.12 - Name and Range Labels

Note

Clicking on the CAZ selection display opens the CAZ Setup screen, with the tab for the current channel selected.

The stop bar icon represents placement of the sensor relative to the approach's stop bar. A stop bar label showing the relative location of the stop bar will be displayed whenever the stop bar is not on the screen.

Click on an alert or zone in the right sidebar to display the corresponding zone(s) in the roadway. Clicking inside a zone rectangle will turn on the name and range labels for the selected zone; click anywhere outside of the zone to turn range labels off.

Various types of detection-related data can be displayed on the tracker on the roadway. The roadway display button is used to select the type of information displayed on the trackers.

Note

Trackers are always colored gray unless a highlight is being applied.

Click and hold on the roadway display selector to access the roadway display mode list (see Figure 8.13).

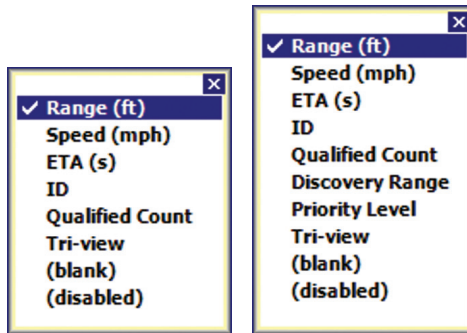

Figure 8.13 – Roadway Display Mode List for Advance (left) and Advance Extended Range (right)

Left-click the roadway display button to cycle forward through the available modes; right-click to cycle backwards through the list (right-clicking is only available on the PC version of the SSMA software).

- **Range (ft)** – Displays the range of the associated tracker to the stop bar.
- **Speed (mph)** – Shows the speed of the associated tracker.
- **ETA (s)** – Shows the tracker’s Estimated Time of Arrival (in seconds) to the stop bar.
- **ID** – Displays the ID number of the associated tracker. SSMA assigns a unique five-digit identification number (1 to 99999) to each tracker.
- **Qualified Count** – The two types of Qualified Count displays available are Qualified Count and Dynamic Density. The data displayed on the trackers depends on the type selected in the Setup CAZ screen.
- **Discovery Range** – Displays the range at which the tracker was first detected. (Only available with SmartSensor Advance Extended Range.)
- **Priority Level** – Shows the priority level assigned to a vehicle based upon its discovery range. Level 1 priority is the highest priority. Level 2 is the highest priority. (Only available with SmartSensor Advance Extended Range.)
- **Tri-view** – Allows up to three user-specified modes to be displayed on each tracker.
- **(blank)** – Removes all data from the tracker displays.
- **(disabled)** – Disables the trackers on the roadway. However, the LEDs in the right sidebar will function as normal.

Note

The disabled mode may be useful when communication is slow or unreliable.

Qualified Count

When the Channel LED is activated in the right sidebar, the Qualified Count value will always be displayed as “---” because a channel may consist of up to 16 zones and the exact meaning of a channel’s Qualified Count is undefined.

When using the Qualified Count display mode, the first number on the tracker represents the number of qualified detections in the zone and the number in parentheses represents the amount of trackers needed to meet the defined requirements. If the number of qualified detections is below the Qualified Count minimum, the number in parentheses is preceded by a “-”; if the number of qualified detections is higher than the Qualified Count maximum, the number in parentheses is preceded by a “+”; if the number of qualified detections is in between the Qualified Count minimum and maximum settings, a “0” is displayed.

Figure 8.14 describes the numbers displayed when the qualified count is lower than, within the limits of, or higher than the specified settings.

Detected Qualified Count	Qualified Count Minimum	Qualified Count Maximum	Displayed Text
1	2	4	01 (-01)
3	2	4	03 (00)
6	2	4	06 (+02)

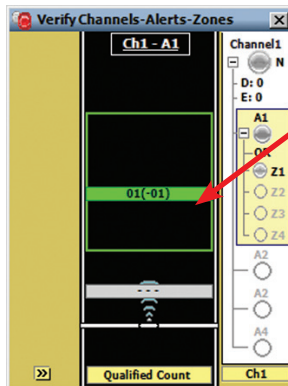

Figure 8.14 – Display Text for Qualified Count Zone Types

Note

When the selected roadway display mode shows the qualified count value on the detection, the tracker highlighting indicates whether the specific detection meets the range, speed, ETA, and priority level qualifications of the associated zone. Highlighting on an individual tracker does not indicate whether or not there are enough qualified detections to satisfy the qualified count filter for the zone.

Dynamic Density

The Dynamic Density parameters determine the number of trackers that are required to meet the specified level of efficiency.

Figure 8.15 describes the text displayed when the Qualified Count is lower than, equal to, or higher than the Dynamic Density thresholds. The number of qualified detections is followed by a percentage number. The percentage is the count ratio of the current number of qualified detections divided by the DDCR (see Figure 8.16).

Detected Qualified Count	Dynamic Density Threshold	Displayed Text
2	4	02 (050%)
4	4	04 (100%)
6	4	06 (150%)

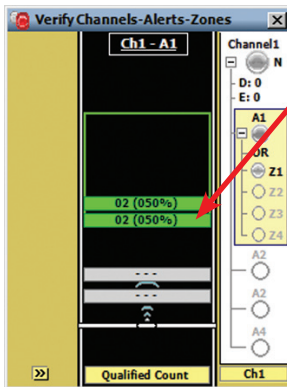

Figure 8.15 – Display Text for Dynamic Density Zone Types

$$\text{Percentage} = \frac{\text{Number of Qualified Detections}}{(\text{DDCR})} \times 100\%$$

Figure 8.16 – Percentage Equation

The zone output will be activated when the count ratio is equal to or greater than 100 percent. The percentage is displayed in the roadway display to help you tune the Dynamic Density parameters and extend the green light when desired.

Note

It is recommended that you adjust the Tuning Factor instead of the Headway and %Utilization parameters.

Tri-view

Configure the tri-view display by clicking and holding on the roadway display selector while the tri-view mode is active. The desired modes can then be selected on the Tri-view Trackers screen (see Figure 8.17).

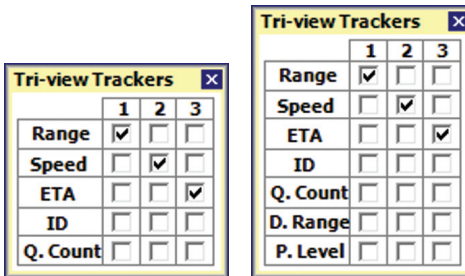

Figure 8.17 – Tri-view Trackers for Advance (left) and Advance Extended Range (right)

The discovery range is abbreviated “D. Range” in the tri-view menu and abbreviated “Disc.” in the selector bar. Priority Level is abbreviated “P. Level” and “Level” respectively.

Any mode can be assigned to display on the left (1), middle (2) or right (3) side of the tracker display (see Figure 8.17 and 8.18). A mode cannot be displayed in more than one location and removing a check mark will disable the corresponding column.

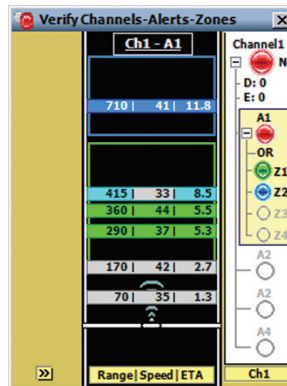

Figure 8.18 – Tri-view Display Mode

Note

The tri-view Qualified Count (Q. Count) data shows only part of the data displayed in the Qualified Count display mode. The Qualified Count displays the count, but does not display the amount of trackers needed to meet the defined requirements; the Dynamic Density displays the percentage, but does not display count.

Clicking anywhere else in the roadway display causes the Select Roadway View screen to appear (see Figure 8.19). This selection screen allows you to select which channel, alert or zone is displayed on the roadway.

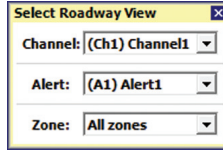

Figure 8.19 – Select Roadway View

When a channel is selected, light blue is used to indicate that that this track meets the range, speed, ETA, and discovery range requirements of at least one of the channel's zones.

It is often useful to select the alert or zone level on the right side bar to better understand how tracker highlighting works. When an alert or zone is selected, the four zone colors are used to indicate that a tracker meets ALL of a zone's range, speed ETA, and discovery range requirements. When verifying alerts or zones, if a tracker is highlighted light blue, this indicates that even though the tracker does not meet ALL range, speed, ETA, and discovery range requirements, it does at least meet the requirement for the currently displayed zone, speed, ETA, discovery range (or priority level) property.

Tracker Highlighting

When a channel, alert or zone is selected on the right sidebar, trackers will be highlighted to help visualize which detections meet range, speed and ETA requirements. This type of visualization can be very helpful when verifying programming logic.

Different highlight colors are applied depending on whether the channel, alert or zone verification has been selected. If a tracker is highlighted, it will be either light blue or the zone color; if a tracker is not highlighted, it will be displayed with the default gray color. Table 8.3 below explains the meaning of each color, based on the sidebar selection.

Sidebar Selection	Tracker Highlight	Description
Channel	Light Blue	Meets ALL range, speed and ETA requirements of one of the channel's zones.
Alert or Zone	Light Blue	Meets a range, speed or ETA zone requirement.
	Z1 - Green	Meets ALL range, speed and ETA zone requirements.
	Z2 - Blue	
	Z3 - Yellow	
Z4 - Red		

Table 8.3 – Tracker Highlighting

When a channel is selected, light blue is used to indicate that this tracker meets the range, speed and ETA requirements of at least one of the channel's zones. This usually indicates that this tracker will activate the channel output. However, this is not always true when Qualified Count, Dynamic Density, zone output inversion or Boolean AND logic is used.

It is often useful to select the alert or zone level on the right side bar to better understand how tracker highlighting works. When an alert or zone is selected, the four zone colors are used to indicate that a tracker meets ALL of a zone's range, speed and ETA requirements. When verifying alerts or zones, if a tracker is highlighted light blue, this indicates that even though the tracker does not meet ALL range, speed and ETA requirements, it does at least meet the requirement for the currently displayed range, speed or ETA property.

The zone highlighting rules also apply to the corresponding sections of the tri-view display. In Figure 8.20 below, the range and ETA display sections are highlighted light blue, meaning that those requirements have been met, but the speed section is not highlighted, meaning that its requirement has NOT been met (and the zone LED is off). When all requirements are met, the entire tracker will turn the zone color.

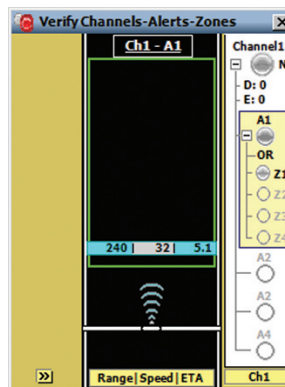

Figure 8.20 - Tri-view Display that Does Not Meet the ETA Filter

Note

When an alert is selected for highlighting, the speed and ETA of the tracker are only highlighted light blue when the vehicle is within the range of the zone. This is necessary when you have multiple zones. However, because discovery range and priority level can only be used with one zone, they can be highlighted before the vehicle reaches the extents of the zone.

Left Sidebar

The left sidebar allows you to view the scale of the roadway and create a tracker log file. Click on the left sidebar selector to cycle through the available views or click and hold on the selector to open the view menu. Below is a list and description of the three views contained in the left sidebar:

- **Hidden View** - Hides the left sidebar and is used to simplify the overall appearance of the Verify CAZ screen.
- **Scale View** - Shows a distance scale relative to the stop bar. The sensor is always displayed at the bottom and is oriented to point towards the top of the screen.
- **Logging View** - Allows you to create a log file (see Figure 8.21). The data can then be post-processed for performance analysis and can be used as the tracker data source when establishing a virtual connection.

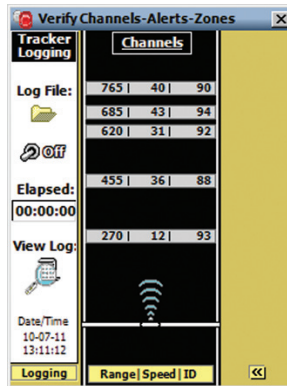

Figure 8.21 – Tracker Logging View

Creating a Tracker Log File

Click on the **Log File** icon to select a log file. The Select Tracker Log File screen allows you to specify the name of an existing log file or to create a new file (see Figure 8.22).

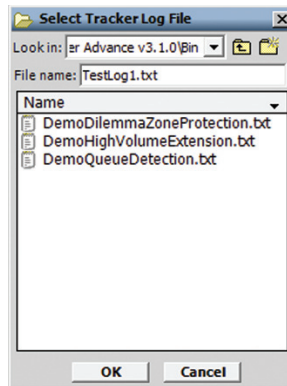

Figure 8.22 – Select Log File

Click the **ON/OFF** toggle switch icon to the ON position to begin tracker logging. Once activated, the duration of the logging session is displayed on the Elapsed: timer display. Click the toggle switch to the OFF position to end a tracker logging session.

The tracker log file is an ASCII text file and can be viewed using a standard text editor. Click on the **View Log** icon to view the current log file using the system's default text editor (see Figure 8.23).

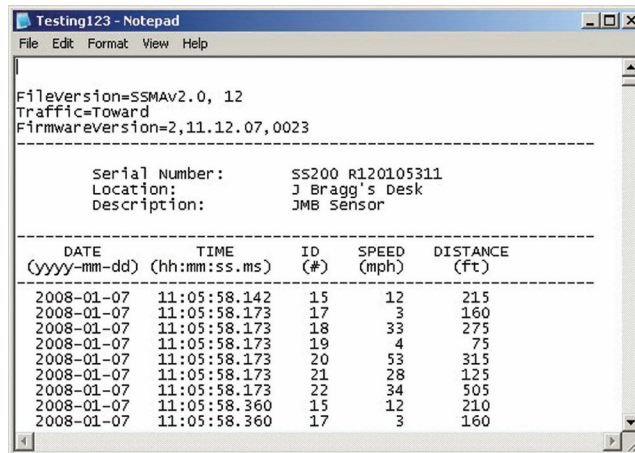

Figure 8.23 – Log File

Setup Output Communications

In this chapter

- Configuring Data Push Parameters

The SmartSensor Advance is normally configured to operate in data push mode on port 2, which means that the sensor initiates each output data transfer, instead of responding to data requests from another device. The features located in the Setup Output Communication screen allow you to configure the data push parameters (see Figure 9.1).

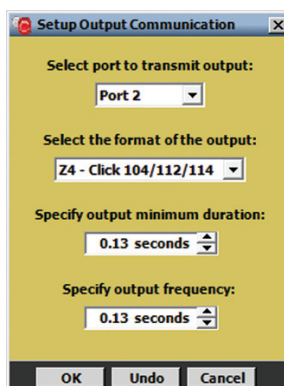

Figure 9.1 – Setup Output Communications

Configuring Data Push Parameters

This section describes the four settings contained in the Output Communication Setup screen.

Select port to transmit output

This control allows you to manually select which of the SmartSensor Advance's communication ports will be used for data pushing. The available options are **None**, **Port 1** and **Port 2**.

In standard installations, Port 2 is an RS-485 port and is designated as the data bus. Data push will automatically be set up when you auto-configure a contact closure card (Click models 100/112/114/172/174). With version 3.0.2 and later, the default port is set at 2 and the default format is Z4 - Click 112/114.

However, you do not have to use the default Port 2. If you select Port 1, be aware that in standard installations, Port 1 is designated as the control bus. For SS200V sensors, the control bus is an RS-485 port usually connected to the bridge port of a Click 222 and is shared with other devices.

The SmartSensor 6-conductor cable is used with SS200V sensors; the blue striped wires are for Port 1 and the orange striped wires are for Port 2. However, remember that with the original SS200 sensor or with the SS200VR (retrofit) sensor, port one is an RS-232 port.

Select the format of the output

This control allows you to manually select which type of data will be transmitted by SmartSensor Advance. The options are:

- Z4 - Click 112/114
- Simple - Click 172/174 (not available for SmartSensor Advance Extended Range)
- Trigger Speed
- Track File

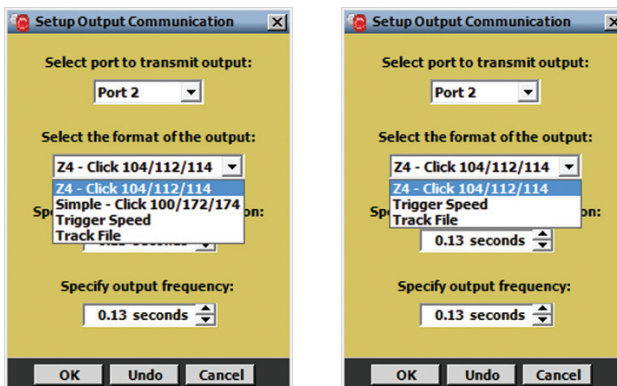

Figure 9.2 - Select Output Format for Advance (left) and Advance Extended Range (right)

Note

SmartSensor Advance Extended Range only works with the Click 112/114/104 cards. It does not work with the Click 172/174/100 cards.

In standard installations, either the first or second option will automatically be selected when you auto-configure an attached Click detector rack card. The first option will be selected if you are using a Click 112/114 and the second option will be selected if you are using a Click 172/174. With version 3.0.2 and later, the default port is set at 2 and the default format is Z4 - Click 112/114.

The **Trigger Speed** and **Track File** options are not used for standard intersection traffic control, but can be used for other applications. The **Trigger Speed** option will push the speed of a detection in Channel 1–Alert 1–Zone 1 each time the channel becomes active. The **Track File** option will push the range and speed of all detections as a heartbeat message.

Specify output minimum duration

This option allows you to specify the minimum output duration in seconds. The minimum output duration is the minimum amount of time that a channel output will be on, even if the output conditions are removed. The selected value should meet the timing requirements of any device in the system that will be processing channel outputs. The default value of 0.13 seconds works well for most devices. The minimum value is 0.01 seconds and the maximum value is 5.00 seconds.

Specify output frequency

This allows you to specify the output frequency of all heartbeat (contact closure & track file) messages in seconds. The specified value determines the time interval between output transmissions. The selected value should meet the timing requirements of any device in the system that will be processing channel outputs. The default value of 0.13 seconds works well for most devices. The minimum value is 0.01 seconds and the maximum value is 1.00 seconds.

The **Undo** button returns all Output Communication parameters to the values they had when the task was started; the **OK** button sends all the Output Communication parameters to the sensor (the settings are not saved to FLASH at this point). Clicking the **Cancel** button will cause you to lose any changes and return to the CAZ menu.

In this chapter

- Creating a Channel Template
- Importing a Channel Template
- Copying and Pasting Channels, Alerts and Zones

Channel templates are optional tools for simplifying frequently-used or standardized channel configurations. A channel template is a text file that contains all the CAZ configuration settings required to completely define a channel. The Import/Create a Template screen allows you to create or import channel templates (see Figure 10.1).

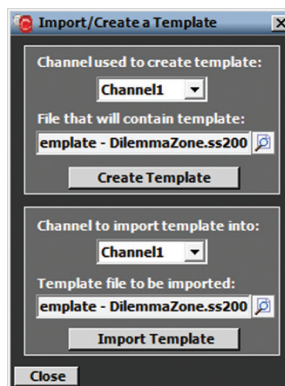

Figure 10.1 - Import/Create a Template

Creating a Channel Template

A template can be created from any of the SmartSensor Advance's eight detection channels. Follow the steps below to specify the channel to be used as a template:

- 1 Select the desired channel from the drop-down list.
- 2 Specify the file to be created by clicking on the file icon (see Figure 10.2).
- 3 Click the **Create Template** button to create the template.

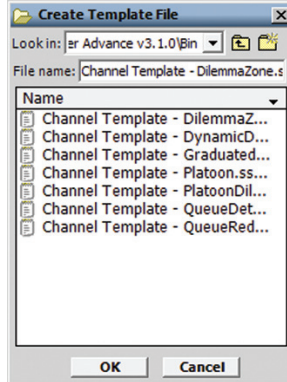

Figure 10.2 – Create Template File Screen

Importing a Channel Template

The SSMA software contains pre-defined channel templates that can be modified to meet your needs. An existing channel template can be loaded into any of the SmartSensor Advance's eight detection channels. Follow the steps below to specify the channel to receive the template:

- 1 Select the desired channel from the drop-down list.
- 2 Specify the file to be imported and click OK (see Figure 10.3).
- 3 Click the Import Template button to load the template. A pop-up screen will appear listing the CAZ elements being modified. A pop-up message will notify you if the template file contains an error.

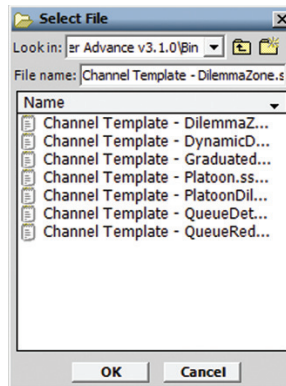

Figure 10.3 – Select Template File Screen

The zone locations described in a channel template are defined to be relative to the stop bar. The stop bar frame of reference allows zones to be described in terms of their traffic-related functions.

However, for a given sensor installation, some zones defined in a channel template may not be entirely within the sensor's detection range. If this is the case, a message will appear stating the number of configured zones that are invalid for the sensor's position relative to the stop bar and you will be prompted to accept the modified results of the imported template or to cancel the import (see Figure 10.4).

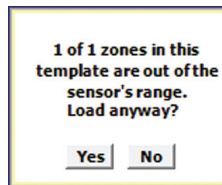

Figure 10.4 – Out of Sensor Range

Templates for channels of type priority can only be imported into a SmartSensor Advance Extended Range device (see Figure 10.5). If you try to import this type of channel into a SmartSensor Advance device you will get the following error:

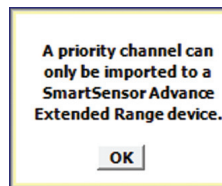

Figure 10.5 – Priority Channel Error

Note

If the modified template results are accepted, the invalid zones will be deleted from the channel configuration. It is strongly advised that you manually inspect the channel configuration and make modifications as required. You should always verify channel performance before terminating the configuration process.

If necessary, the desired template can be copied and modified in a text editor to accommodate the sensor's position, or the channel can be configured in the software.

Changes that have not been written to FLASH memory will be lost the next time the sensor reboots.

Copying/Pasting Channels, Alerts and Zones

In some cases it may be useful to copy and paste a channel, alert or zone. To copy a channel, right-click on the Channel tab and select Copy Channel; to paste a channel, right-click on the Channel tab and select Paste Channel (see Figure 10.5).

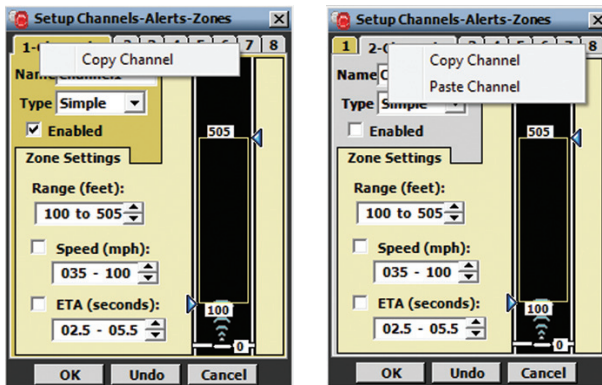

Figure 10.6 – Copying (left) and Pasting (right) CAZ Elements

Note

To copy and paste CAZ elements using a Pocket PC, press and hold the stylus on the Channel, Alert or Zone tab and select **Copy** or **Paste**.

In this chapter

- Backup/Restore Tool
- Beam Alignment Tool
- Serial Terminal
- Rack Card Tools

The Tools screen allows you to backup and restore sensor settings, visualize the sensor alignment and communicate with the sensor using a serial terminal (see Figure 11.1).

The Tools job varies depending on whether or not SSMA is connected to a sensor. The only tool available when SSMA is not connected to a sensor is the Serial Terminal tool.

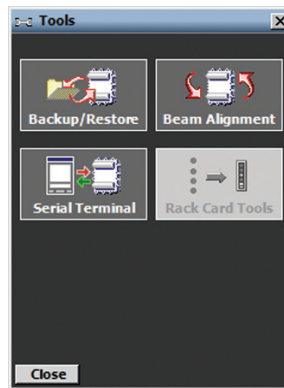

Figure 11.1 - Tools Screen

Backup/Restore Tool

Click the **Backup/Restore** icon to start the Backup/Restore tool (see Figure 11.2). To specify either a backup or restore file, click on the corresponding magnifying glass icon to open the Choose File screen. Enter or select the desired file name and click **OK**.

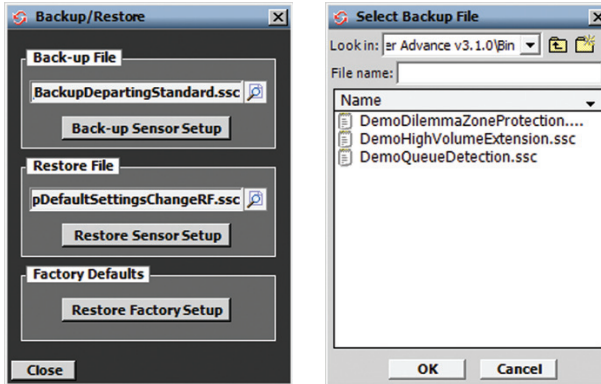

Figure 11.2 – Backup/Restore Screen (left) and Choose File Screen (right)

Once the proper file has been specified, you can start the backup or restore operation.

Backing Up the Configuration

Click the **Back-up Sensor Setup** button to save the current configuration. The **Select Settings to backup** screen allows you to specify which types of configuration data will be backed up (see Figure 11.3). Make changes by checking or unchecking specific settings.

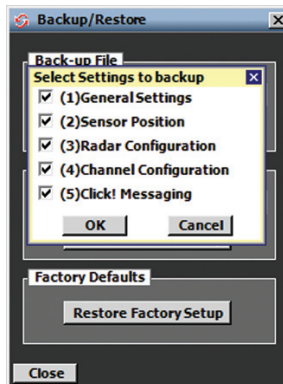

Figure 11.3 – Select Settings to Backup Screen

Click **OK** to obtain the sensor's configuration data and begin the backup process, or click **Cancel** to return to the Backup/Restore screen.

Restoring the Configuration

Click the **Restore Sensor Setup** button to load a configuration and overwrite the current configuration. The **Select Settings to restore** screen allows you to specify which types of configuration data will be restored (see Figure 11.4). Make changes by checking or unchecking specific settings.

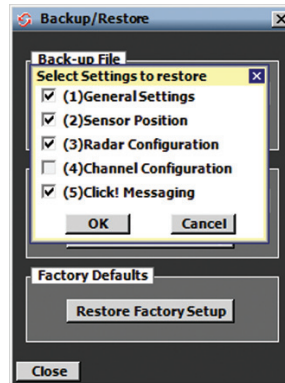

Figure 11.4 - Restore Settings

Configuration categories that are not defined in the restore file are grayed out and may not be selected for restoration. Click **OK** to perform the backup process and save the new settings to FLASH. Click **Cancel** to return to the Backup/Restore screen.

Note

If the serial baud rate being restored is different than the baud rate being used for the current connection, you will be prompted to accept the new baud rate or keep the existing baud rate.

If an error occurs, the configuration file may be invalid and the message shown in Figure 11.5 will be displayed. Clicking **Yes** will reboot the sensor and reload the last configuration that was saved to FLASH; click **No** to try again.

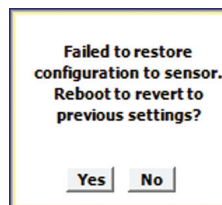

Figure 11.5 - Restore Configuration Error

Note

You cannot restore a backup file from a SmartSensor Advance device to a SmartSensor Advance Extended Range device. The converse is also true.

If the restore process completes successfully, the configuration was loaded and saved to FLASH.

The zone locations described in a configuration file are relative to the stop bar. The stop bar frame of reference allows zones to be described in terms of their traffic-related functions. However, it is possible for some zone problems to arise if the channel configuration is restored but the sensor position is not.

For a given sensor installation, some zones defined in a configuration file may not be entirely within the sensor's detection range. If this is the case, a message will appear stating the number of configured zones that are invalid for the sensor's position relative to the stop bar and you will be prompted to accept the modified results of the restored configuration or to cancel the restore altogether (see Figure 11.6).

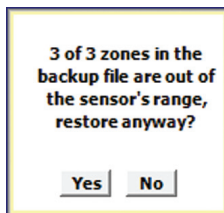

Figure 11.6 – Out of Sensor's Range

Note

If the modified template results are accepted, the invalid zones will be deleted from the channel configuration. It is strongly advised that you manually inspect the channel configuration and make modifications as required. You should always verify channel performance before terminating the configuration process.

If necessary, the desired configuration file can be copied and modified in a text editor to accommodate the sensor's position; or the channel can be configured using the software.

Restoring to Factory Defaults

To restore the device to its factory defaults, use the **Restore Factory Defaults** button on the Backup/Restore page.

The following window will pop up asking you to confirm that you want to restore the sensor to factory defaults:



Figure 11.7 – Restore to Factory Defaults

The process should take only a few seconds. If it is successful you will see a success message. Otherwise, you will see a failure message.

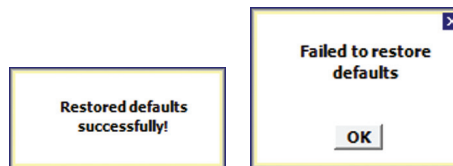

Figure 11.8 – Restore Defaults Results

Beam Alignment Tool

Click the **Beam Alignment** icon to start the Beam Alignment tool (see Figure 11.9). This tool is used to help the person installing the sensor to visualize the invisible radar beam footprint, based on the sensor mounting offset and mounting height.

By default, the values in the recommended alignment table (see Appendix D and Table D.1) are now entered automatically when the Alignment Tool screen first appears. The alignment tool values will be correct only if you have correctly put height and offset information in the 1. Installation Details screen.

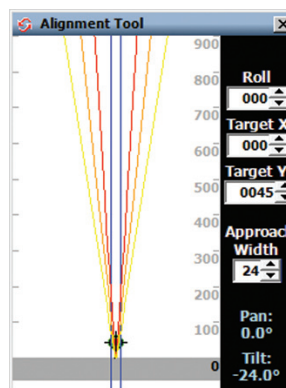

Figure 11.9 – Beam Alignment Tool

Note

The Alignment Tool page shows a 900-foot range, regardless of sensor type.

Note

This screen is purely a visualization tool and does NOT modify the sensor configuration in any way. The range scale along the right side of the display is sensorcentric (i.e. range starts at 0 and goes to 600 ft).

Below is a list and description of the alignment tool features:

- **Roll** – The angle that the sensor is rotated using the backplate center axis (clockwise = positive; counter clockwise = negative).
- **Target X** – The target distance as shown in Figure 1.3 and Tables 1.1 and D.1 (see Chapter 1 and Appendix D). This is the downstream distance of the target location (beam hot spot). The target is depicted on the roadway view with cross-hairs and a light-green color.
- **Target Y** – The offset as shown in Figure 1.3 and Tables 1.1 and D.1 (see Chapter 1 and Appendix D).
- **The Approach Width** – This value allows you to make the virtual roadway (blue lines) wider or narrower to match the width of the approach.
- **Pan** – The angle that the sensor is rotated about its vertical axis (right = positive; left = negative).
- **Tilt** – The angle that the sensor is rotated about its horizontal axis. Only down angles (negative angles) are supported.

Note

A properly-scaled screen capture of the footprint drawing can be used as an overlay on roadway CAD drawings.

Serial Terminal

Click the **Serial Terminal** icon to start the Serial Terminal tool. The serial terminal provides a rudimentary terminal interface that can be used to communicate with the sensor using a com port (see Figure 11.10).

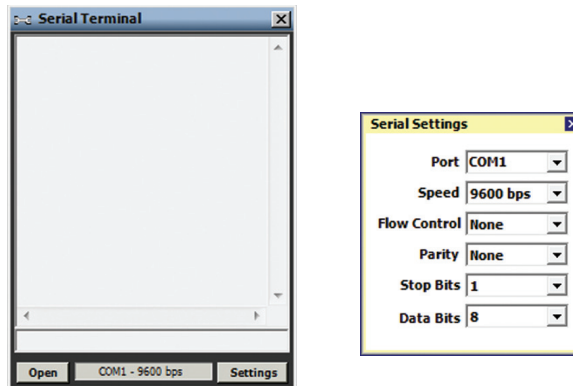

Figure 11.10 – Serial Terminal (left) and Serial Settings (right)

Click the **Settings** button to configure the serial port for the terminal session. The resulting Serial Settings screen allows you to specify the typical serial port parameters. Click the X in the upper right corner to save the settings.

Once the port is configured, click **Open** to open terminal session.

Note

If a connection is attempted using a com port that is already in use by the system, a warning message is displayed. You must either free the selected com port or select another com port for the terminal session.

To send data to the attached sensor, type an SS200 command in the Tx (Transmit) window located on the bottom of the Serial Terminal screen. Each SS200 command must be terminated with a carriage return (0x0D), which is accomplished by pressing the **Return** or **Enter** key. Transmitted commands are displayed in the both the Tx and Rx (Receive) window and are paired with any associated response. Any additionally received commands are also displayed in the Tx/Rx Window. Scroll up/down and left/right through the terminal session data using the scroll bars in the Rx Window.

Click **Close** to close the terminal session; click the X in the upper right corner to leave the serial terminal (this also closes the terminal session and releases the com port).

Rack Card Tools

Access rack card tools by clicking the **Rack Card Tools** button on the Tools screen when a sensor connection is NOT active (see Figure 11.11).

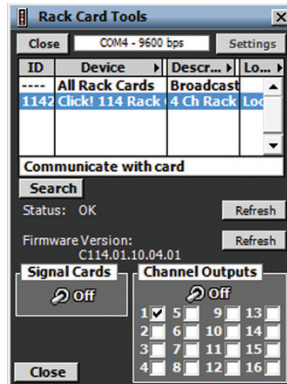

Figure 11.11 – Rack Card Tools

The Rack Card Tools screen allows you to verify that you have the correct channel mapping into the traffic controller, without being connected to a sensor. Serial data messages sent by the rack card tool reach the rack cards via a T-bus and the patch cord connections from the Click 222 control bridge to the contact closure cards.

Since this tool can be used without a sensor, it can reduce the amount of time spent on-site when installing a SmartSensor Advance system. You can use the rack card tool to verify rack card connections while cable is being pulled through conduit or the sensors are being installed.

Note

When used with SmartSensor Advance, the rack cards should be configured to communicate at the default 9600 bps. If you are having communication issues, you may want to verify that the rack cards and the sensor are configured to communicate at 9600 bps.

Using the Rack Card Tool

To search for Click 112/114 rack cards using the rack card tool:

- 1 Click on the **Settings** button and select the correct communications port and baud rate.
- 2 After you have entered the correct settings, close the Serial Settings window and click the **Search** button.
- 3 Once a list of devices appears, click on the desired row. You can identify a device by its ID, Device, Description or Location fields. If you would like to communicate to all the devices, select **All Rack Cards** in the device column.

Status

The **Status** field indicates whether the rack card is operating normally or whether it is in fail-safe mode. If the device is in fail-safe mode, the text message may help you understand why the device is in fail-safe. For example, if the text reads “Failsafe Initializing,” this indicates that the rack card has never seen any detection call messages since it was rebooted. If the message reads “Failsafe Timeout (No Data),” this indicates that the rack card was previously receiving detection calls, but hasn’t received any in the last 10 seconds or more.

Firmware Version

The **Firmware Version** field lists the version of the rack card firmware. When you would like to refresh the status of these fields, click the associated **Refresh** button. If you are communicating with all devices, the status and firmware version fields are not applicable (N/A).

Signal Cards Switch

You can use the **Signal Cards** toggle switch to help single out devices. When the switch is ON, all main menu LEDs on the selected devices will begin flashing. If you have selected **All Rack Cards**, then the main menu LEDs of every card connected on the bus will begin flashing.

Channel Outputs Switch

The **Channel Outputs** toggle switch and 1–16 checkboxes are used to help assist in testing of the rack card outputs. Even though the SmartSensor Advance only has 8 outputs, the 16 outputs are shown because SmartSensor Advance and SmartSensor Matrix can share the same control bus. This tool allows you to test communications to rack cards from either sensor.

If the **Channel Outputs** switch is ON, all the selected channel outputs on the Click 112/114 rack card will be active. The LEDs that indicate an active output channel will light up accordingly. An output will only be active when the corresponding box is checked.

Note

When the Rack Card Tool connects, it will disable data push on all sensor ports. This will normally put the rack card tool into fail-safe mode until you manually activate channel outputs or close the connection.

The **Channel Outputs** switch can be very helpful in verifying the I/O channel mapping from the rack card outputs to the traffic controller inputs. By sequentially checking boxes 1–16, you should be able to quickly verify the mapping of each channel, even in the absence of traffic.

In this chapter

- Click 112/114 Contact Closure Cards
- Click 172/174 Contact Closure Cards
- Click 104 DIN Rail Module

Once the sensor has been installed and configured, the detections will be recorded in a controller through the use of contact closure modules. The Click 112/114 and 172/174 cards are specifically designed to easily integrate the SmartSensor Advance with existing NEMA TS1, TS2, 170 and 2070 controllers.

Click 112/114 Contact Closure Cards

You can use SmartSensor Advance and SmartSensor Advance Extended Range with the Click 112/114 contact closure cards using the Z4 protocol. Communication from the sensor can be set up by the cards or by using SmartSensor Manager.

To connect and autobaud to the detector rack cards:

- 1 Connect from the Click 222 RS-485 A port to a bus 1 port on the appropriate rack card. Connect from the Click 222 RS-485 B port to a bus 1 port on another rack card.
- 2 If you are using Click 112 cards, use a patch cord to share bus 1 between cards dedicated to the same sensor. If you have more than two sensors in your system, repeat steps 1–3 to connect bus 1 for all remaining rack cards.
- 3 Connect from a Click 222 bridge port to bus 2 of the rack cards.
- 4 Daisy-chain between the bus 2 ports of all of the rack cards for device configuration.
- 5 Verify that detections are registering on the Channel LEDs.

Note

For information about how to configure the Click 112/114, see the Click Series User Guide or the Click 112/114 Quick-Reference Guide.

Communication via SmartSensor Manager

To setup communication via SmartSensor Manager:

- 1 From the Channel-Alerts-Zone screen, click on **Setup Output Communication**.
- 2 Select **Port 2** from the transmit output drop-down list. Port 2 is the data bus and is an RS-485 port.
- 3 Select **Z4 - Click 112/114** from the output format drop-down list to set up communication with a Click 112/114.
- 4 Click **OK** to save the communication changes.
- 5 Verify that detections are registering on the rack card and close SmartSensor Manager if you are connected over the data bus.

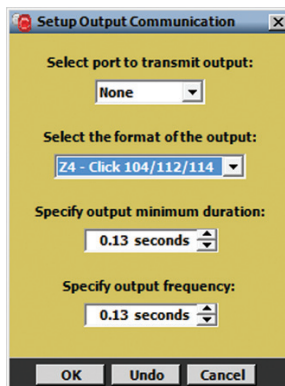

Figure 12.1 - Setting Output Communications Using SmartSensor Manager

Click 172/174 Contact Closure Cards

The Click 172/174 cards are simple to program and require little on-site maintenance (see Figure 12.2).

Note

The SmartSensor Advance Extended Range only works with the Click 112/114/104 card. It does not work with the Click 172/174/100 cards.

Note

A Click 100 16-output contact closure module can be used if the cabinet you are connecting to does not have an input file rack.

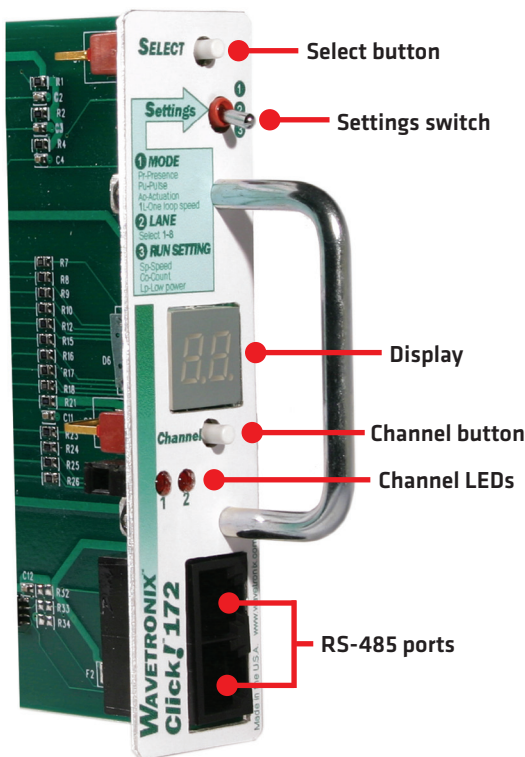

Figure 12.2 – Click 172/174 Cards

To program the Click 172/174 contact closure cards:

- 1 Plug the surge card into the input file rack. Make sure the Settings switch is in the 3 position when plugged in. Wait approximately 20 seconds.
- 2 Move the Settings switch to the 1 position and after the auto-baud is complete, the current mode will appear.
- 3 Toggle the Select button to select AC or Actuation mode.
- 4 Move the Settings switch to the 2 position and wait a few seconds.
- 5 Move the Settings switch to the 3 position.
- 6 Wait approximately 30 seconds and then confirm that the detections are registering on the Channel LEDs.

In many cases, you can put multiple alerts on each channel to avoid the need for more than

two channels. If you would like to use more than two channels, you will need a 4-channel card or you will need to daisy-chain rack cards together.

Note

It is recommended to select a channel order using the sensor configuration software, rather than using step 2 of the rack card.

Fail Safe Mode

If the rack card is in fail-safe mode (constant call on all channels), you can check connectivity by connecting an RS-485 to RS-232 converter (Click 304) to the T-bus expansion slot on the traffic cabinet assembly. The sensor's RS-232 port is completely independent and may become unreliable at communication lengths greater than 200 ft. (61 m).

Rack Card Dip Switch

If you are seeing calls on the rack card LEDs, but do NOT see them registering in your controller, you may need to disable the rack card's pull-up circuitry. To do so, use the dip switch on the rack card circuit board. If pull-up is enabled, the rack card will pull its back-plane contact pins high when the contact is open. However, if pull-up is disabled, the rack itself will need to pull the contact pins high when the contact is open. In either case, when a contact closure occurs, it is the responsibility of the rack card to pull the associated contact pin low (see Figure 12.3).

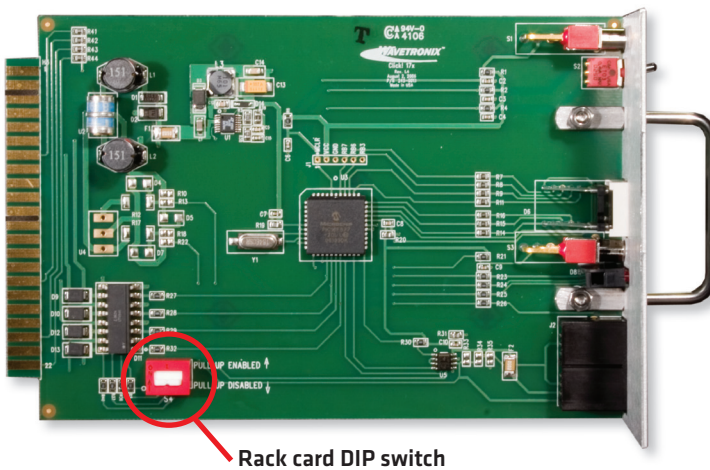

Figure 12.3 – Dip Switch on the Click 172/174 Cards

Once the contact closure card is configured, the controller's detector inputs must be set up and then assigned to the correct phases of the intersection.

For more information about the Click 172/174 contact closure cards, contact Wavetronix Technical Services.

Click 104 Contact Closure Module

The Click 104 contact closure device is similar to the Click 114 in that they both have four output channels, but differs in that it is a DIN rail-mounted device, rather than a rack card, making it useful for installations that have no detector racks.

Note

The Click 104 has four output channels. If you need more output channels than that, you'll need to use multiple Click 104s and daisy-chain them together.

Follow the steps below to connect to your Click 104:

- 1 Connect a patch cable to the Click 222 RJ-11 jack for the sensor you want to get data from. Connect the other end to either of the RJ-11 jacks on the faceplate of the Click 104.
- 2 If you are using multiple Click 104s, you'll need to daisy-chain them together. This is why there are two RJ-11 jacks on the Click 104. Connect a patch cable from the second RJ-11 jack on the first Click 104 to an RJ-11 jack on the second Click 104. Repeat this as many times as needed to connect all necessary Click 104s. These extra 104s will need to have their channel input mapping changed; more on that later.
- 3 If there are multiple sensors that need to be taken care of, repeat this steps using the other data RJ-11 jack on the Click 222 (and, if necessary, on other Click 222s; for instance, for a four-sensor intersection, you'd need two Click 222s to cover all four sensors).

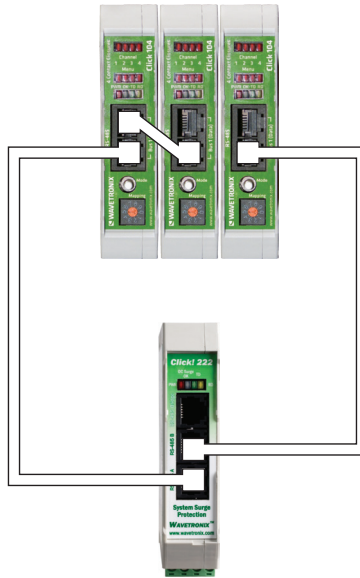

Figure 12.4 – Click 104 Wiring Diagram

Note

If you're using the Click 223, you only need to follow steps 1 and 2 twice, as those devices only connect to a single sensor.

Click 104 Configuration

You can configure the Click 104 with Click Supervisor, using the front panel menu or using the rotary switch. Each configuration option allows you to change different parameters; some parameters can only be configured using one option, while others can be configured using any of the three. Table 12.1 below gives you an idea of which parameters can be configured using which configuration options.

	Rotary Switch	Front Panel Menu	Click Supervisor
Baud Rate	No	Yes	Yes
Channel Input Map	Yes	Yes	Yes
Autobaud	No	Yes	No
Reset to Default	No	Yes	Yes
Description	No	No	Yes
Location	No	No	Yes
Device ID	No	No	Yes
Fail-safe Settings	No	No	Yes
To use this configuration option:	Hardware mode	Software mode	Software mode

Table 12.1 – Click 104 Configuration Options

If you have used the rotary switch to set the channel input mapping (which is the only thing you can do with the rotary switch), that mapping cannot be set or changed with the front panel menu or Click Supervisor. If the rotary switch is set to 0, you can set channel input mapping using Click Supervisor or the front panel menu.

Note

If any setting has been set using both the front panel menu and Click Supervisor, whichever configuration was set most recently will be the one that counts.

See the *Click 100–400 Series User Guide* for more information on these contact closure devices.

Appendix

In this chapter

- A - Cable Connector Definitions
- B - Cable Lengths
- C - Direct Serial Connections
- D - Target Roll Angles for Alignment

Appendix A – Cable Connector Definitions

The connector end of the SmartSensor 6-conductor cable mates to the 8-pin connector on the SmartSensor Advance (see Figure A.1).

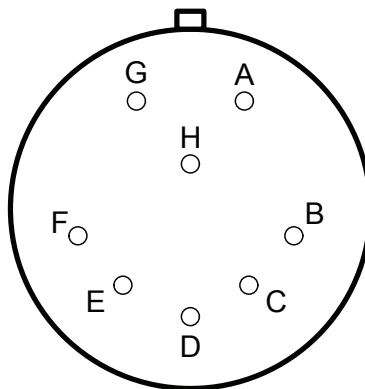

Figure A.1 – SmartSensor Advance Connector

The SmartSensor 6-conductor cable has seven wires. Table A.1 details the pinout of the

cable connector and the corresponding wire in the cable. The sensor itself also contains internal wires that connect to the protective earth lug.

Pin	Cable Wire	Signal Description
A	Red	DC+
B	Orange and white stripe	Data bus 485+ (Sensor port 2)
C	Orange	Data bus 485- (Sensor port 2)
D	Drain / Shield	Drain
E	Blue and white stripe	Control 485+ (Sensor port 1)
F	Blue	Control 485- (Sensor port 1)
G	Black	Common (Ground)
H	----	Reserved

Table A.1 – Pinout for Power and Communication Signals

Creating Custom Cables

Proper connector crimping tools are necessary to create custom cables. The SmartSensor 6-conductor cable connector uses a MILC-C-26482 Series 1 connector, crimping contacts and a watertight back shell. A kit with these parts can be ordered directly from Wavetronix.

Size 20 contacts are used to accommodate the 20 and 22 AWG wires in the cable. (The SmartSensor 6-conductor cable's red and black wires provide a 20 AWG wire pair. The other pairs on the SmartSensor 6-conductor cable are 22 AWG and are normally used for communication.)

Follow the steps below to create a custom cable (see Figure A.2):

- 1** Slide the strain relief, follower, grommet and back shell over the cable.
- 2** Strip the cable jacket and shielding back about 1 1/2 in. (4 cm).
- 3** Strip each of the seven SmartSensor cable wires back about 1/4 in. (0.6 cm).
- 4** Insert the wires into the contacts and verify the wire is visible through the contact inspection hole.
- 5** Crimp the wires by following the crimping tool instructions. Daniels Manufacturing Company provides professional grade crimping tools and detailed instructions on crimping. Wavetronix recommends the DMF AF8 M22520/1-01 or equivalent tool for crimping.
- 6** Manually press the contacts into the back side of the connector plug.
- 7** Use a DMC DAK20 (or equivalent) insertion tool to fully seat the contact into the connector plug. Check the mating face of the connector to ensure that all the contacts are fully inserted. A DMC DRK20 extractions tool (or equivalent) is necessary to remove a misplaced or misaligned contact.
- 8** Thread the back shell onto the connector plug. To keep the connector from rotating during the threading process, connect the plug and coupling ring to a sensor connector

receptacle.

- 9 Press all of the connector parts together. Thread the strain relief onto the back shell.
- 10 Tighten the strain relief screws on the back.



Figure A.2 – Connector Sub-assembly Parts

Appendix B – Cable Lengths

Maximum cable lengths are dependent on both power and communication requirements. In some cases, it may be beneficial to use wire pairs, normally designated for communications, for power instead. This may make sense in applications where only one communication port is needed. In this case, you can extend the distance of power by adding a communication wire pair to the power wire pair. In addition, since the power requirements for the SmartSensor Advance model SS200V are lower than those for the SmartSensor Advance model SS200, the maximum cable lengths are longer.

Maximum Cable Length for Powering SS200V

The following recommendations allow you to provide reliable power to the SmartSensor. The SmartSensor cable's red and black wires provide a 20 AWG wire pair. The other pairs on the SmartSensor cable are 22 AWG and are normally used for communication.

The table below shows the cable lengths for power when using a SmartSensor Advance model SS200V (see Table B.1):

Cable Gauge	24 Volts	12 Volts
20 AWG (6-conductor)	1500 ft. (457.2 m)	300 ft. (91.44 m)
Add 485+/485- (6-conductor)	2450 ft. (746.76 m)	500 ft. (152.4 m)
14 AWG	6500 ft. (1.98 km)	1300 ft. (396.24 m)
12 AWG	9000 ft. (2.74 km)	1800 ft. (548.64 m)
10 AWG	13700 ft. (4.18 km)	2800 ft. (853.44 m)

Table B.1 – Maximum Cable Length for Power (model SS200V)

If the cable length is longer than 1500 ft. (457.2 m) when operating at 24 V, it is possible to increase the maximum cable length by wiring a pair of lines normally used for RS-485 communications with the red and black wires.

Maximum Cable Length for SS200V Communications

To achieve reliable wired communications, the selected baud rate must be compatible with the length of the cable run. The table below shows the cable length recommendations for wired communications (see Table B.2):

Baud Rate	RS-485
115.2	300 ft. (91.4 m)
57.6	600 ft. (182.9 m)
38.4	800 ft. (243.8)
19.2	1000 ft. (304.8 m)
9.6	2000 ft. (609.6 m)

Table B.2 – Maximum Cable Length for Wired Communications

Given the power and communication requirements listed above, here is a summary of some power and communication cable guidelines (see Table B.3):

Length	Cable	Comm. Channel 1	Comm. Channel 2
0–1500 ft. (0–457.2 m)	6-conductor Cable	Native RS-485	Native RS-485
1500–2000 ft. (457.2–609.6 m)	6-conductor Cable	Native RS-485	NA
2000–2500 ft. (609.6–762 m)	Alternate cable for power and communications	Native RS-485	Native RS-485

Table B.3 – Summary of SS200V standard cable length options

Maximum Cable Length for Powering SS200

The table below shows the cable lengths for power when using a SmartSensor Advance model SS200 (see Table B.4):

Cable Gauge	24 Volts	12 Volts
20 AWG (9-conductor)	600 ft. (182.88 m)	110 ft. (33.52 m)
Add RTS/CTS (9-conductor)	1000 ft. (304.8 m)	185 ft. (56.38 m)
Add TD/RD (9-conductor)	1400 ft. (426.72 m)	260 ft. (79.24 m)
14 AWG	2500 ft. (762 m)	450 ft. (137.16 m)
12 AWG	3900 ft. (1.18 km)	700 ft. (213.36 m)
10 AWG	6000 ft. (1.82 km)	1050 ft. (320.04 m)
8 AWG	9900 (3.01 km)	1750 ft. (533.4 m)
6 AWG	14000 (4.26 km)	2500 ft. (762 m)

Table B.4 – Maximum Cable Length for Power (model SS200)

If the cable length is longer than 600 ft. (182.88 m) when operating at 24 V, it is possible to increase the maximum cable length by wiring a pair of lines normally used for RS-232 communications with the red and black wires.

If the cable length is 200 ft. (61 m) or greater you cannot reliably use RS-232 communications. To add 400 ft. (121.9 m) and achieve a maximum cable length of 1000 ft. (304.8 m), connect the orange wire (normally RTS) to the red wire and the brown wire (normally CTS) to the black wire.

If your cable run is longer than 1000 ft. (304.8 m), it is possible to sacrifice additional communication pairs to increase the maximum cable length for power. However, you may desire to communicate to the sensor over two independent channels, in which case you will need to consider an alternate cable for power. The AWG for wire pairs that achieve a 2000-ft. (609.6-m) maximum cable length or greater at 12 and 24 V are listed in Table B.5.

Maximum Cable Length for SS200 Communications

To achieve reliable wired communications, the selected baud rate must be compatible with the length of the cable run. The table below shows the cable length recommendations for wired communications (see Table B.5):

Baud Rate	RS-232	RS-485
115.2	40 ft. (12.2 m)	300 ft. (91.4 m)
57.6	60 ft. (18.3 m)	600 ft. (182.9 m)
38.4	100 ft. (30.5 m)	800 ft. (243.8)
19.2	140 ft. (42.7 m)	1000 ft. (304.8 m)
9.6	200 ft. (61 m)	2000 ft. (609.6 m)

Table B.5 – Maximum Cable Length for Wired Communications

To provide two independent communication channels with a homerun cable length over 200 ft. (61 m), convert the RS-232 data into RS-485 using a Click 304 in a pole-mount cabinet mounted next to the sensor. In this case, the homerun connection establishes one RS-485 channel over the normal white/blue wire pair and another RS-485 channel over the yellow/violet wire pair. An additional Click 304 is needed to convert the data sent over the yellow/violet wire pair back to RS-232 before connecting to surge protection.

If you elect to use an alternate cable for power, you may also want to select an alternate cable for RS-485 communications. Some options include the Belden 3105A (Paired – EIA Industrial RS-485 PLTC/CM) or Alpha Wire 6010C 3PR 22 AWG.

Given the power and communication requirements listed above, here is a summary of some power and communication cable guidelines (see Table B.6).

Length	Cable	Comm. Channel 1	Comm. Channel 2
0-200 ft. (0-61 m)	SmartSensor Cable (9-conductor)	Native RS-485	Native RS-232
200-1000 ft. (61-304.8 m)	SmartSensor Cable (9-conductor)	Native RS-485	Click Conversion of RS-232 to RS-485
1000-1400 ft. (304.8-426.7 m)	SmartSensor Cable (9-conductor)	Native RS-485	NA
1400-2000 ft. (426.7-609.6 m)	Alternate power and communications cable	Native RS-485	Click Conversion of RS-485 to RS-232

Table B.6 – Summary of SS200 standard cable length options

Appendix C – Direct Serial Connections

For most applications, the service end of the SmartSensor cable terminates in a surge protection device. However, during demonstrations, troubleshooting, and certain other situations, it is sometimes convenient to bypass surge protection and connect directly to a personal computer or communications device such as a modem.

Older sensors and the retrofit SmartSensor Advance are configured as an RS-232 DTE device. To connect the SmartSensor cable’s RS-232 wires directly to another DTE device (such as a PC), you can use a standard 9-pin D connector and a null modem cable. To connect directly to a DCE device (such as a modem), you will need a straight-through cable. Figure C.1 illustrates both of these cases.

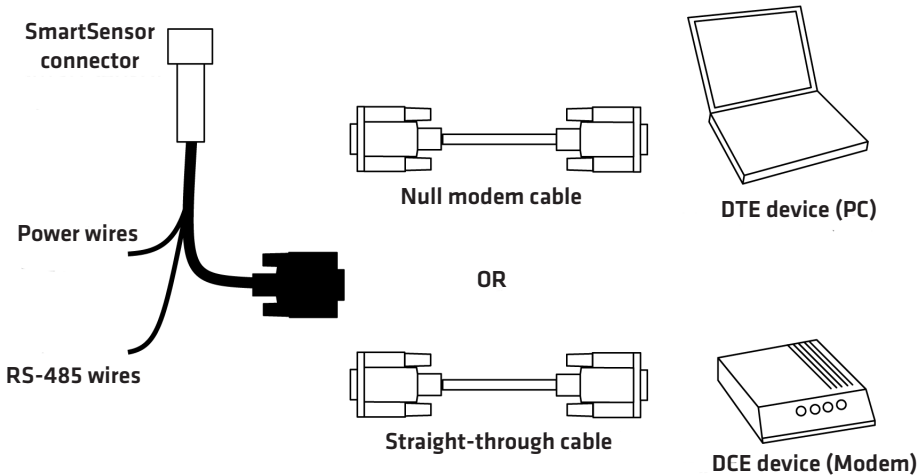

Figure C.1 – Direct Serial Connections

Note

If you do not have the right type of RS-232 physical connection you will not be able to connect using the SmartSensor Manager software. Since null modem cables and straight-through cables look similar, you may want to label them. Alternatively, you may want to use a null modem adapter instead of a null modem cable. If you do, you can turn your straight-through cable into a null modem cable by attaching the adapter on one end.

If you wish to connect the SmartSensor cable's RS-485 wires directly to a PC or modem, this will require that these devices natively support RS-485 communications. Often, modern personal computers do not support RS-485 communications and support USB communications instead. If your computer only supports USB communications, you may want to use a Click serial to USB converter to make a direct connection.

Appendix D – Target Roll Angles for Alignment

The following appendix provides quantitative information about how far the sensor should be rolled during installation.

The following table is similar to Table 1.1, except that it lists a target roll angle in addition to a target distance (see Table D.1). For example, if the sensor were mounted 30 ft. (9.1 m) high with a 50-ft. (15.2-m) offset, the target distance would be 110 ft. (22.9 m) and the target roll angle would be 66°.

It is helpful to know that in some cases during installation the sensor could be rolled so that it appears to be the laying virtually on its side. Using Table D.1 will help you achieve the full detection potential of the sensor.

		Height (ft/m)											
		17/5.2		20 /6.1		25 /7.6		30/9.1		35/10.7		40 /12.2	
Offset (ft / m)		Y	Roll	Y	Roll	Y	Roll	Y	Roll	Y	Roll	Y	Roll
	0/0	40	0°	45	0°	55	0°	60	0°	70	0°	75	0°
	5 /1.5	45	19°	45	16°	60	13°	65	12°	70	10°	80	9°
	10/3	50	35°	50	31°	60	25°	65	22°	75	19°	80	17°
	15/4.6	50	47°	55	42°	65	36°	70	32°	75	28°	80	24°
	20/6.1	55	56°	55	51°	65	44°	75	39°	80	35°	90	32°
	25/7.6	60	62°	65	57°	65	51°	75	46°	80	41°	90	38°
	30/9.1	65	67°	70	63°	75	56°	80	51°	85	47°	95	43°
	35/10.7	70	71°	75	67°	85	61°	85	56°	95	52°	95	48°
	40/12.2	80	74°	90	71°	90	65°	95	60°	95	57°	100	52°
	45/13.7	95	76°	100	73°	100	68°	100	64°	100	59°	105	56°
50/15.2	100	78°	100	76°	105	71°	110	66°	115	62°	120	59°	

Table D.1 – Target Roll Angle

Note

If you would like to narrow the coverage of the sensor at far ranges, consider reducing the target location by about 25%. For example, if your current target location is 40 ft, you could reduce it to around 30 ft. Or, if your target location is 120 feet, you could reduce it to around 90 feet. This can be helpful if you have significant roadside clutter.

The information in this table was derived using the Alignment Tool in the configuration software (see Figure D.1). You can use this tool to see the effects of a sensor that is not properly aligned. The goal is to have the red contour (half power level contour) line up and down the roadway over the lanes of interest. Chapter 8 of this document gives information related to the use of the alignment tool.

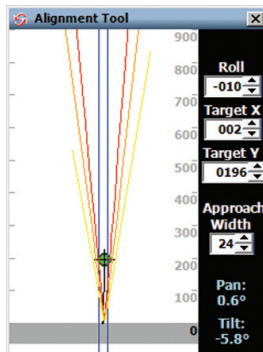

Figure D.1 – Alignment Tool

