

DWG. NO.
PHCU4W

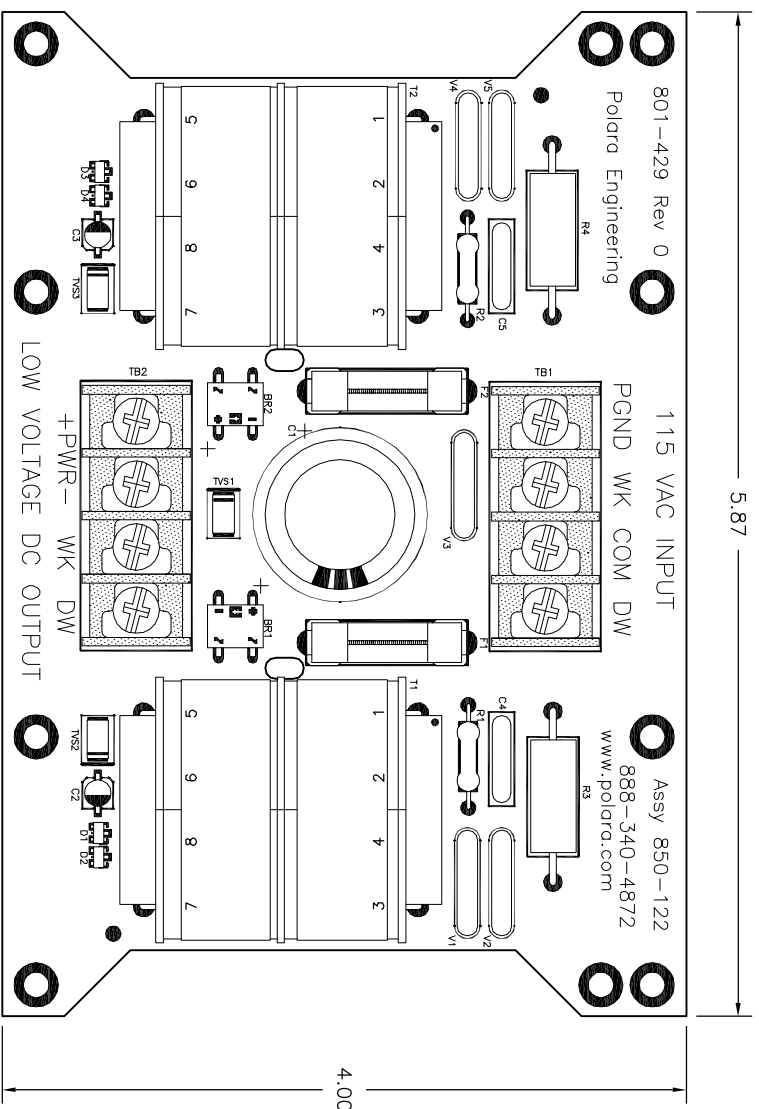

SPECIFICATIONS

INPUT CONNECTIONS: 115VAC, Walk, Don't Walk, Common, Protective Ground, from wiring inside a pedestrian sign (Ped Head).

OUTPUT CONNECTIONS: Approximately 20 Volts DC, Positive and Negative Power, Walk and Don't Walk, to a 4 Wire Push Button Station. The PCHU4W is provided with 2 mounting brackets and hardware which allow easy mounting inside all common types of pedestrian signs. It uses two ¼ amp 5x20mm fuses. It has built in surge protection and is epoxy coated for moisture protection. There are no settings or adjustments.

Revised - 01/06/04

REV. DATE	LTR	E.C.O. NO.	BY	CKR	ENG	DSN	MFG	QA	FNL

POLARA ENGINEERING INC.
4115 W. ARTESIA AVE. FULLERTON, CA. 92833

TOLERANCES: .XXX ±.005 .XX ±.02 (EXCEPT AS NOTED) SCALE NONE

DRAWN BY	CKR.	ENG. MGR.	MFG. MGR.	SHEET	OF
BB				1	1
DATE	DSN. ENG.	Q.A. APP.	FINAL APP.	USE	
09-08-03				4W NAV	
TITLE	4 WIRE POWER UNIT			DWG. NO.	PHCU4W

INFORMATION ON THIS DOCUMENT IS NOT TO BE USED, COPIED, REPRODUCED OR DISCLOSED IN WHOLE OR IN PART WITHOUT WRITTEN CONSENT OF POLARA