

## Model XAV2 & XAV2-LED System Installation

This document provides instructions for installing the Polara Push Button Station (PBS) and the XAVCU2 or XAVCU2-DC Control Unit.

### Mounting the Push Button Stations

Use the provided mounting hole diagram on page 7 to drill and tap the pole for the PBS. The maximum recommended distance from the ground to the center of the push button is 39 inches. Less than 39 inches is acceptable.

The PBS comes with the button arrow pointing in a certain direction. The button arrow can be made to point left, right, or up, depending on the location of the PBS on the pole. The arrow should always point through the crosswalk. For example, if you stand facing the button and the crosswalk is on your left, the arrow should point to the left. If the crosswalk is directly in front of you, the arrow should point up. If the crosswalk is on the right, the arrow should point to the right.

Remove the sign from the PBS by removing the four attachment screws. If the arrow direction is correct, there is no need to open the unit. If the arrow needs to be changed, remove the 6 cover screws and carefully bring the cover to approximately 60° which frees the bottom hinge, then remove the cover. Place the cover on a flat surface with the backside facing you (see the sketch below). To change the arrow direction, loosen the 4 screws holding the diaphragm 1-2 turns each. Press on the front of the button and turn it counter-clockwise until it pops out. Orient the arrow in the desired direction then replace the diaphragm so each tab sits in its pocket with a corner under each screw head. Tighten each screw making sure the diaphragm is not pinched between the screw and cover. The screw head is intended to keep each tab in its pocket. The screw must not bind the tab preventing it from moving freely. Reinstall cover and six screws. **Be careful not to drop the cover and break the hinge.**

Turn while lightly pressing on button from other side to remove.

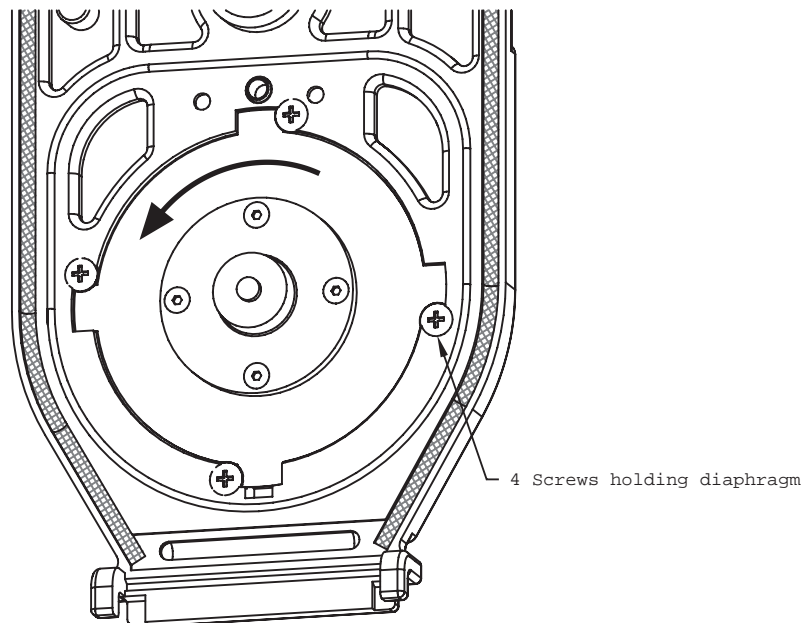

Route the cable into the pole either downward to an access hole, or upward and out the top of the pole. If the XAVCU2 control unit will mount on the same pole, then, route the cable to the XAVCU location. Attach the PBS to the pole using the supplied ¼-20 bolts and washers. Re-attach the sign as shown in the sketch.

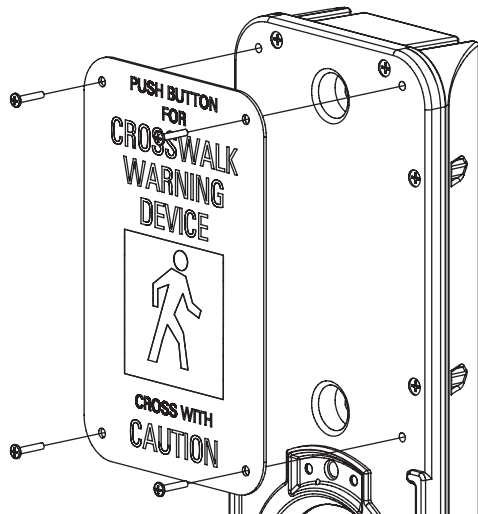
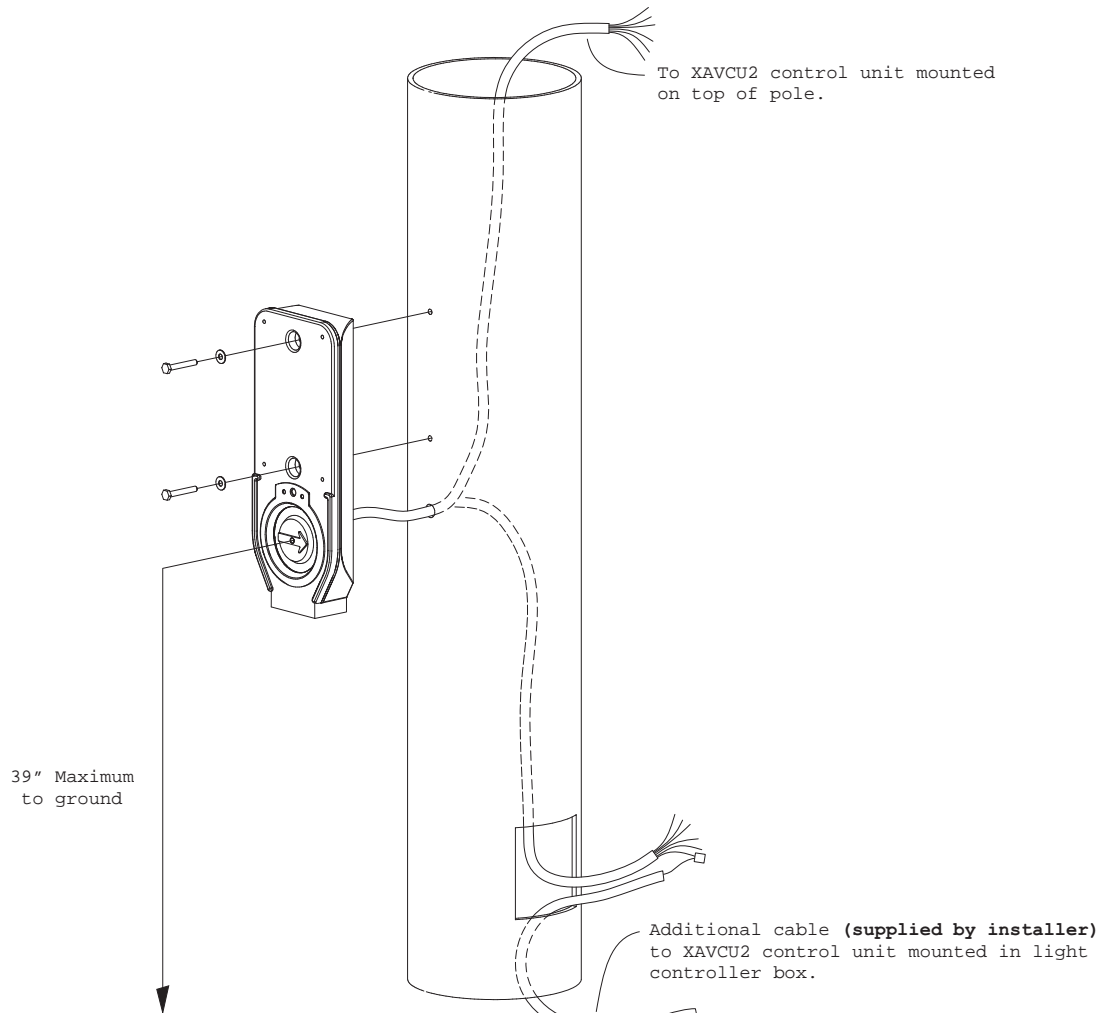

## Mounting the XAVCU2 Control Unit

The XAVCU2 is typically installed in the same protective enclosure as the light flashing control system, but if it is mounted on the pole or any other location, it must be in a NEMA 4 or equivalent moisture proof protective box.

For mounting within the light flashing control system enclosure, locate a suitable space for the XAVCU2 board inside the same enclosure. The board measures 6.5" x 4.5" and has four mounting holes on 5.4" x 3.9" centers. Drill and attach with four screws.

## Wiring (Refer to the accompanying wiring diagram)

The Model XAV2 system uses 8 conductor cabling between the PBS and control unit. If the PBS and XAVCU2 are mounted on the same pole, then the PBS cable may attach directly to the XAVCU2. Otherwise additional cable is required. Polara recommends a direct burial suitable cable with AWG 18 stranded conductors and matching color coding (Belden 27601A). Polara stocks this cable which can be purchased separately.

The 8 conductor cable connects to the 8 terminal blocks along the bottom edge of the XAVCU2. The terminal blocks are labeled with the color of the wire that connects to the block. Each block has two connections which are connected in parallel for easy connection of two PBS units. Strip about 1/4" of insulation off each wire to connect to the terminal block. The functions of the terminal blocks are also marked to aid in troubleshooting so that in case of trouble, you may be able to identify the wires associated with the problem.

If additional cable is used, then splicing is necessary. Polara provides 3M Part No. UAL cable splicing connectors for this purpose. These connectors are compatible with the PBS cable and the Belden AWG 18 cable.

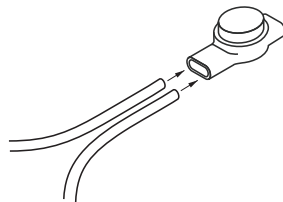

To make the splice, insert the unstripped ends of the matching color into the connector as far as they will go. Then use pliers to compress the button down approximately flush with the connector body. Splice all 8 wires of matching colors. Note that two of the wires have a black stripe so make sure these are correctly matched.

Two connections (4 wires) are required between the XAVCU2 and the crosswalk flashing system. The first is the push button input that triggers the flashing. This wire pair should connect to the BUTTON OUT terminals on the XAVCU2. Next is a flashing signal from the flash control. This signal should turn on and off with the flashing lights visible to street traffic. It could be the actual voltage feeding the flashing lights. The voltage may be 10 - 135 volts, AC or DC. The wire pair should connect to the LTS IN terminals. One wire connects to COM and the other to the terminal best matching the voltage present on the wire (10-35V or over 35V). It is this signal which triggers the audible message from the XAV2 system.

## DC MODEL

If you are installing the XAVCU2-DC, connect a DC source of 10-24 volts to the DC INPUT POS and NEG terminals. **If the DC source is two 12 volt batteries in series, connect the XAVCU-DC to only one of those batteries to avoid exceeding 24 volts.** Otherwise, connect 115 VAC to the AC INPUT LINE and NEUT terminals. If an earth ground wire is available, connect it to either EARTH terminal.

# WIRING DIAGRAM

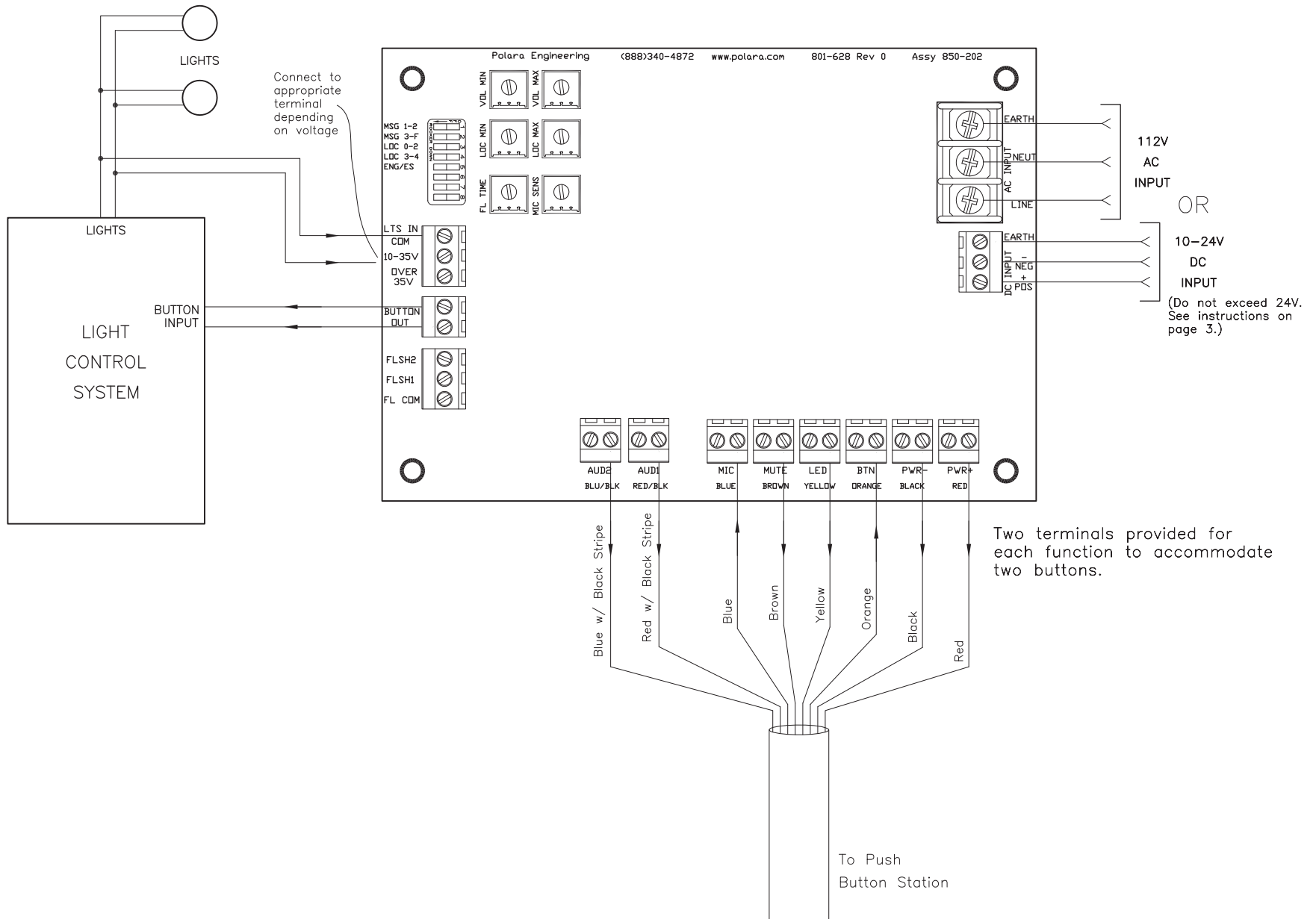

## Operation

The XAVCU2 has two LED indicators. The red PWR LED flashes once per second and indicates that the board has operating power and the on-board microcontroller is functioning. The red BUTTON LED indicates whenever a PBS button is pressed and activated.

### MESSAGE REPEAT SELECTION

Dip switch positions 1 and 2 are used to select the number of message repeats whenever flashing starts.

SW1	SW2	Result
OFF	OFF	1 Repeat
ON	OFF	2 Repeats
OFF	ON	3 Repeats
ON	ON	Continuous while flashing

If any of the message repeats, 1, 2, or 3, is selected, then any button push during the flashing will restart the message count.

### LOCATE TONE SELECTION

Dip switch positions 3 and 4 are used to configure the PBS locating tone.

SW3	SW4	Result
OFF	OFF	No Locate Tone
ON	OFF	Locate tone every 2 seconds
OFF	ON	Locate tone every 3 seconds
ON	ON	Locate tone every 4 seconds

### MESSAGE SELECTION

Dip switch position 5 selects the message type.

SW5	Result
OFF	English Language Only
ON	English message followed by Spanish message

## Volume Control

The output volume from the XAV2 system is chosen automatically based on the ambient noise level received by the microphone. The volume can self-adjust over a wide range. A microphone sensitivity (MIC SENS) control can increase or decrease the volume change due to a change in ambient noise. MIN and MAX controls are provided for both voice message and locate tone. These adjustments restrict the volume range chosen by the microphone control. The MIN control sets the lower limit for the volume and the MAX control sets the upper limit. If both controls are set the same, or the MAX is set below the MIN, the volume will be fixed. The MAX control takes precedence over the MIN.

## Troubleshooting Information

The following are descriptions of the XAVCU2 terminals to help identify sources of trouble.

**PWR+ TERMINAL** - This point should always have a DC voltage present. For the XAVCU2, this voltage should be 13 to 15 volts most of the time. It will typically fluctuate some if the voice message is currently playing. For XAVCU2-DC, the voltage should match the DC INPUT voltage. This voltage is measured between PWR+ and PWR-.

**PWR- TERMINAL** - This is the circuit ground for the XAV2 system.

**BTN TERMINAL** - Connecting this terminal to ground (PWR-) should cause the BUTTON LED to light and cause the BUTTON OUT terminals to change to a low resistance state between them. Pressing the PBS button should cause the voltage at the BTN terminal to drop to near zero.

**LED TERMINAL** - This is an output from the XAVCU2 to the PBS. It's an open collector type output that connects to ground to turn on the PBS LEDs. This output should turn on the LEDs whenever the voltage is present at the LTS IN input.

**MUTE TERMINAL** - This is an output signal which switches the audio amplifier in the PBS between operate and standby modes. It should go to ground whenever a sound is to be played.

**MIC TERMINAL** - This is a low voltage signal from the PBS which represents the ambient noise level. It is generally less than 1 volt above ground and can range from 0 to 1.5 volts. It should change as the ambient noise changes.

**AUD1, AUD2** - This is a balanced audio signal which provides the input signal to the audio amplifier.

**FLSH COM, FLSH1, FLSH2** - Output signals for driving external flash relays. These are typically not used, and are intended for special order applications.

**BUTTON OUT** - Solid state opto-relay contact closure while BUTN terminal is grounded.

**LTS IN** - Input from an external flash controller. This signal must be present in order to trigger the voice message and also to flash the PBS LEDs.

### **IMPORTANT!**

1. The message will not play without proper inputs from light flashing controller on "LTS IN".
2. Check to see that the striped "RED/BLK" and "BLU/BLK" and non-striped "RED" and "BLUE" wires are not mixed with each other. All wires should be connected to their appropriate matching color.

# MOUNTING HOLE DIAGRAM FOR PUSH BUTTON STATION

When printing document in Adobe Acrobat, be sure that "None" is selected in Print Scaling in the printing dialog box to ensure that document is printed to the correct scale. Otherwise, recreate template using dimensions shown.

